

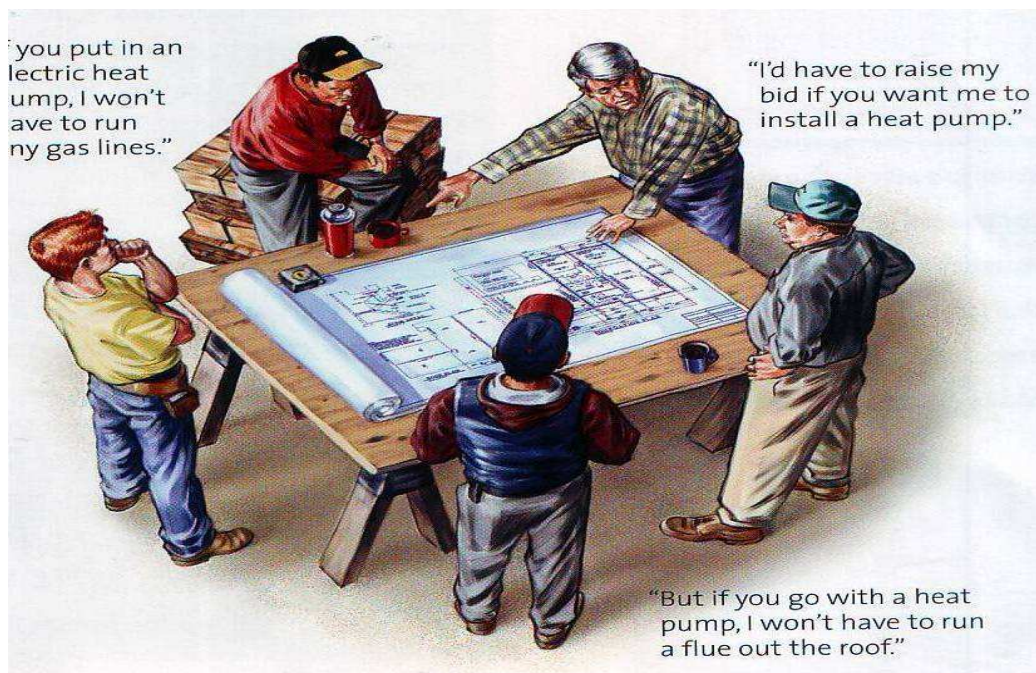

## NATIONAL DIPLOMA IN QUANTITY SURVEYING



### INTRODUCTION TO MEASUREMENT

COURSE CODE: QUS 101

YEAR I - SEMESTER I

THEORY/MEASUREMENT

## GENERAL OBJECTIVES:

1.0	Understand the history of Quantity Surveying
2.0	Understand the duties and functions of a Quantity Surveying
3.0	Know standard method of Measurement of building works
4.0	Understand in detail the knowledge of Measurement

# TABLE OF CONTENTS

## General Objectives

- 1.0 History of quantity surveying and the duties of the quantity surveyor
  - 1.1 Roots in Britain
  - 1.2 Development of the Standard Method of measurement
  - 1.3 History of quantity surveying in Nigeria
  - 1.4 The Nigerian standard method of measurement
  - 1.5 Recent developments in quantity surveying
  - 1.6 Duties of the quantity surveyor
- 2.0 The role of the various professionals in the construction process
  - 2.1 The quantity surveyor
  - 2.2 The Architect
  - 2.3 The structural, services and building engineer
  - 2.4 The civil engineer
  - 2.5 Professional bodies and regulatory bodies
- 3.0 The Standard Method of Measurement
  - 3.1 The Standard Method of Measurement
  - 3.2 The Building and Engineering Standard Method of Measurement
  - 3.3 General rules
- 4.0 Building and engineering standard method of measurement general rules I
  - 4.1 Quantities
  - 4.2 Descriptions
  - 4.3 Framing work item descriptions
  - 4.4 Drawn information
  - 4.5 Catalogues and standard components
  - 4.6 Fixing base and backgrounds
  - 4.7 Procedure when inadequate information is provided
  - 4.8 Symbols and abbreviations

- 5.0 Building and engineering standard method of measurement general rules II
  - 5.1 Cross referencing
- 6.0 Building and engineering standard method of measurement general rules III
  - 6.1 Cross referencing
- 7.0 Measurement procedures
  - 7.1 Taking-off
  - 7.2 Descriptions
  - 7.3 Spacing of dimensions
- 8.0 Applied Mensuration I
  - 8.1 Introduction
- 9.0 Applied Mensuration II
  - 9.1 Relationship between shapes and building measurement
- 10.0 Centre line girth I
  - 10.1 Introduction
- 11.0 Centre line girth II
  - 11.1 Rectangular plan with recess
- 12. Centre line girth III
  - 12.1 More complex shapes
- 13. BESMM3 Rules for Excavation and Earthworks I
  - 13.1 Work Group D - Groundwork
- 14. BESMM3 rules for Excavation and earthworks II
  - 14.1 Classification rules
- 15. BESMM3 Rules for Excavation and earthworks III
  - 15.1 More classification rules

# WEEK 1: HISTORY OF QUANTITY SURVEYING & DUTIES OF THE QUANTITY SURVEYOR

## 1.1 Roots in Britain

The Quantity Surveying profession has its root in Britain during the 17<sup>th</sup> century although the earliest recorded firm, Henry Cooper and Sons of Reading was established in 1785. The first recorded use of the term “quantity surveyor” was in 1858.

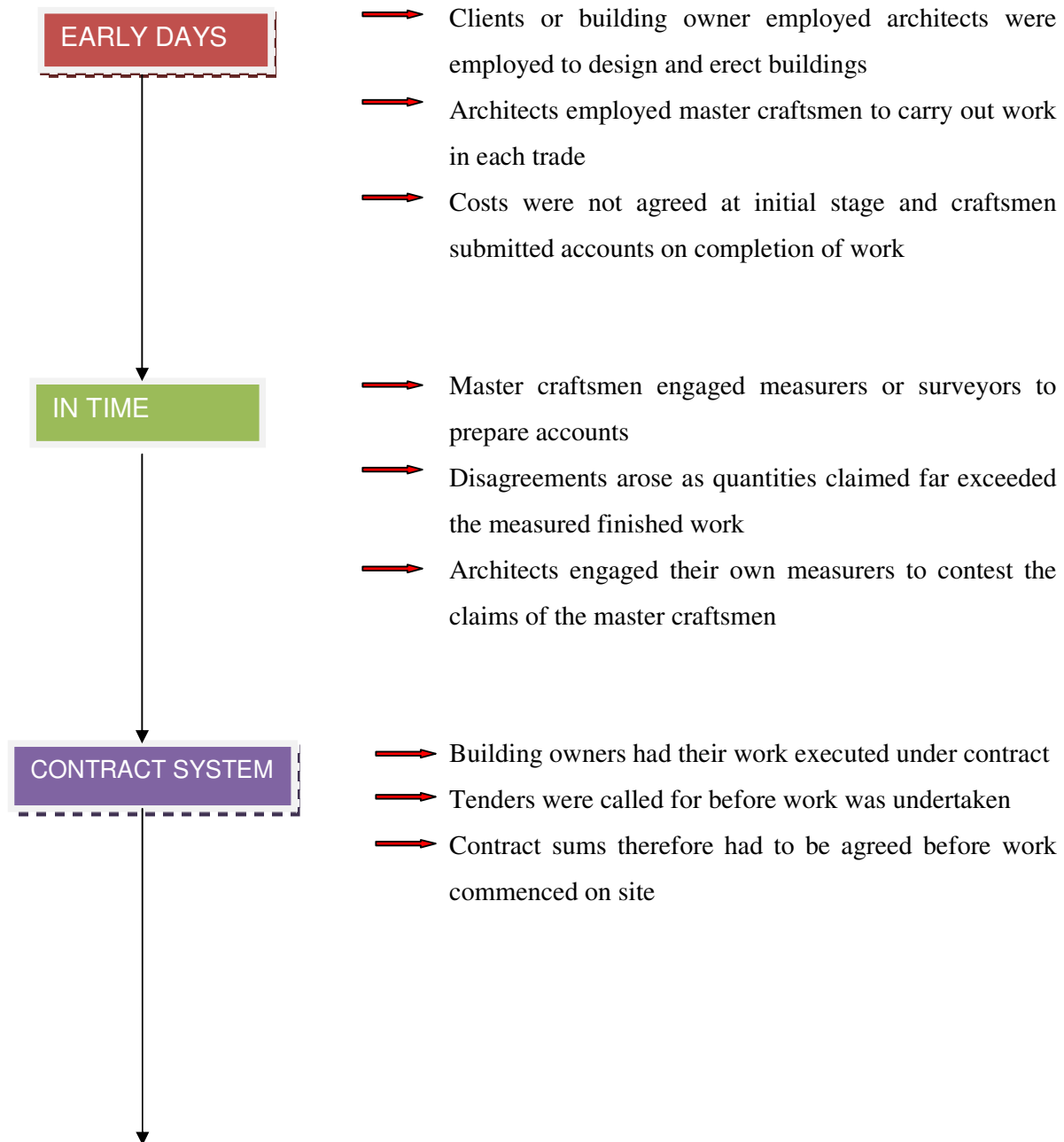

## INDUSTRIAL REVOLUTION

System of building procurement gained strength  
Advent of the general contractor who submitted inclusive estimates covering all the trades  
Full drawings and specifications were prepared before tenders were called for  
Contractors tendered in competition with one another based on the full drawings and specifications

## THE BILL OF QUANTITIES

The only way to prepare an accurate estimate cost or tender is to measure the quantities of all the labour and materials necessary to complete the works – in other words, preparing a “bill of quantities”.

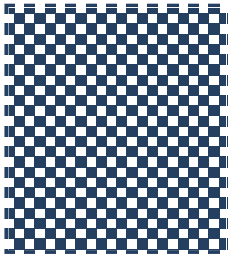

Initially each builder prepared his own bills of quantities for each project, later it was considered more economical for all of them as a group to employ one surveyor to measure the quantities for them all.  
The cost of engaging the surveyor was shared  
They would obtain an identical bill of quantities ensuring that all contractors were pricing and tendering on the same basis.

→ The client employed his own surveyor to work with the contractors' surveyor and protect his interests

## THE INDEPENDENT QUANTITY SURVEYOR

→ With time, the building owner found it to be to his own advantage to appoint and pay the fees of the quantity surveyor.

This was the origin of the independent and impartial quantity surveyor as it is found today.

## 1.2 Development of the Standard Method of Measurement

- Up to the middle of the nineteenth century, it was the practice to measure and value the building work after it had been completed and bills of quantities were not prepared.
- Dispute points in connection with building works were decided by the Surveyor's Institution and the Quantity Surveyors' Association.
- The frequency with which they were called to decide on areas of conflict pointed at the necessity of achieving greater accuracy of work and uniformity of method.

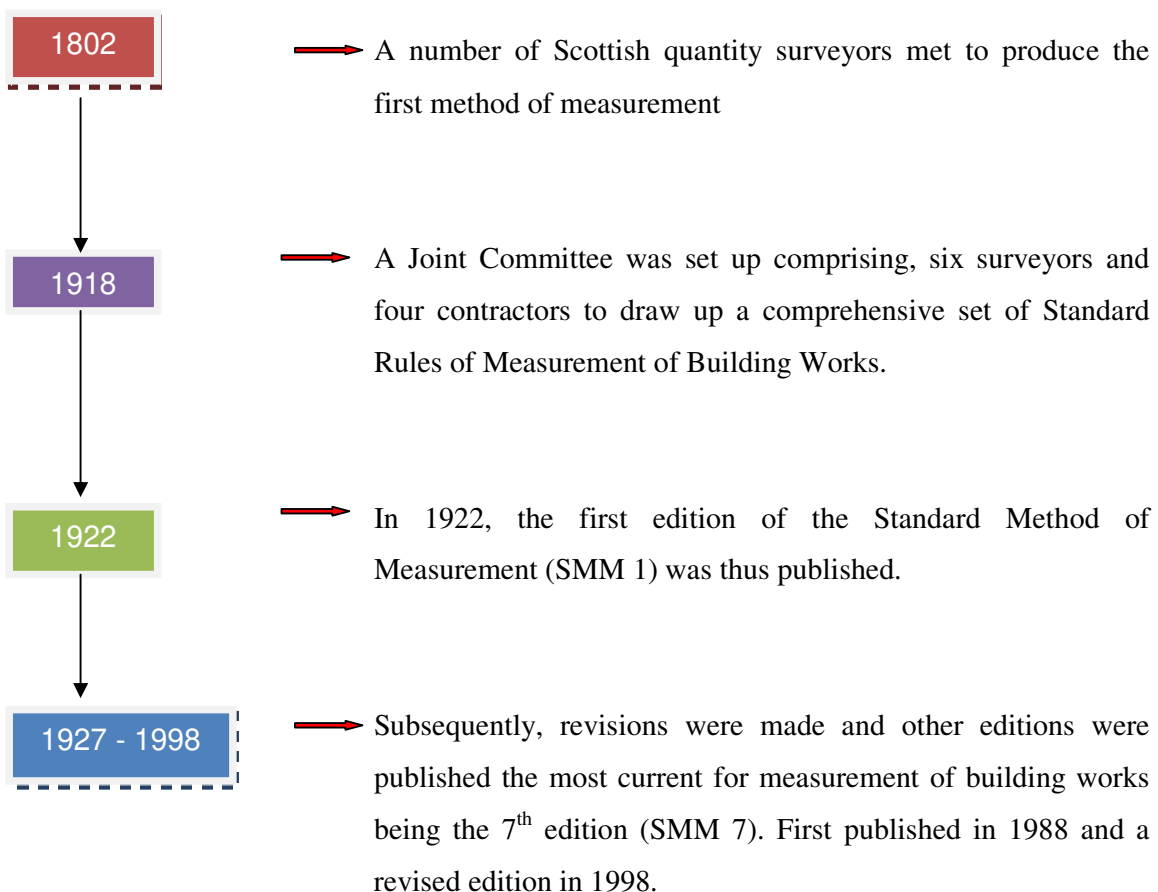

## 1.2.1 Standard Methods of Measurement for Other Classes of Work

### 1.2.1.1 Civil Engineering Works

1991

→ The 3<sup>rd</sup> Edition of the Civil Engineering Standard Method of Measurement (CESMM3) for use in the measurement of civil engineering works was produced by a joint committee under the auspices of the Institution of Civil Engineers and the Federation of the Federation of Civil Engineering Contractors of Britain.

### 1.2.1.2 Industrial and Process Engineering Works



The Royal Institution of Chartered Surveyors published the Standard Method of Measurement of Industrial Engineering Construction, SMMIEC which is used in the measurement of heavy and process engineering works.

## 1.3 History of Quantity Surveying in Nigeria

Quantity Surveying originated in Great Britain and was imported into Nigeria by the British who colonised Nigeria. It can be implied that the first set of quantity surveyors who practised in Nigeria were British citizens.

The first set of Nigerian quantity surveyors trained in Britain in the early 50s

This set of Nigerian quantity surveyors started returning to Nigeria in the 60s

By 1968 enough of them had returned to enable them set up an association to develop the practice of the profession in Nigeria.

Thus, the Nigerian Institute of Quantity Surveyors (NIQS) was founded in 1969.

Mr. Victor Akan is recorded as the first Nigerian Quantity Surveyor

The first recorded Nigerian owned quantity surveying firm was founded in 19 .



TRAINING IN NIGERIA

- ➔ Soon after its formal set up, the Institute initiated efforts for the education and training of quantity surveyors in Nigerian tertiary institutions.
- ➔ Ahmadu Bello University was the first university to start running the degree programme in 1971 graduating its first set in 1974.
- ➔ Auchi Polytechnic was the first polytechnic to commence the diploma programme in quantity surveying in .

GOVERNMENT RECOGNITION

- ➔ The government of Nigeria is the largest client of the profession
- ➔ Government recognised the quantity surveying profession as one of the scheduled professions in 1978 under the Regulated and other Professions Act.
- ➔ Decree 31 of 1986 and CAP 383 LFRN 1991 gave legal backing to the quantity surveying profession and also set up the Quantity Surveyors' Registration Board of Nigeria to regulate the profession

PRACTICE IN NIGERIA

- ➔ Practice of the profession of quantity surveying in Nigeria is along the same pattern as in Britain and other commonwealth countries.
- ➔ The standard methods of measurement published in Britain are largely in use in Nigerian practices starting with the fifth edition of the SMM for building works and the second edition of the CESMM.

## 1.4 The Nigerian Standard Methods of Measurement

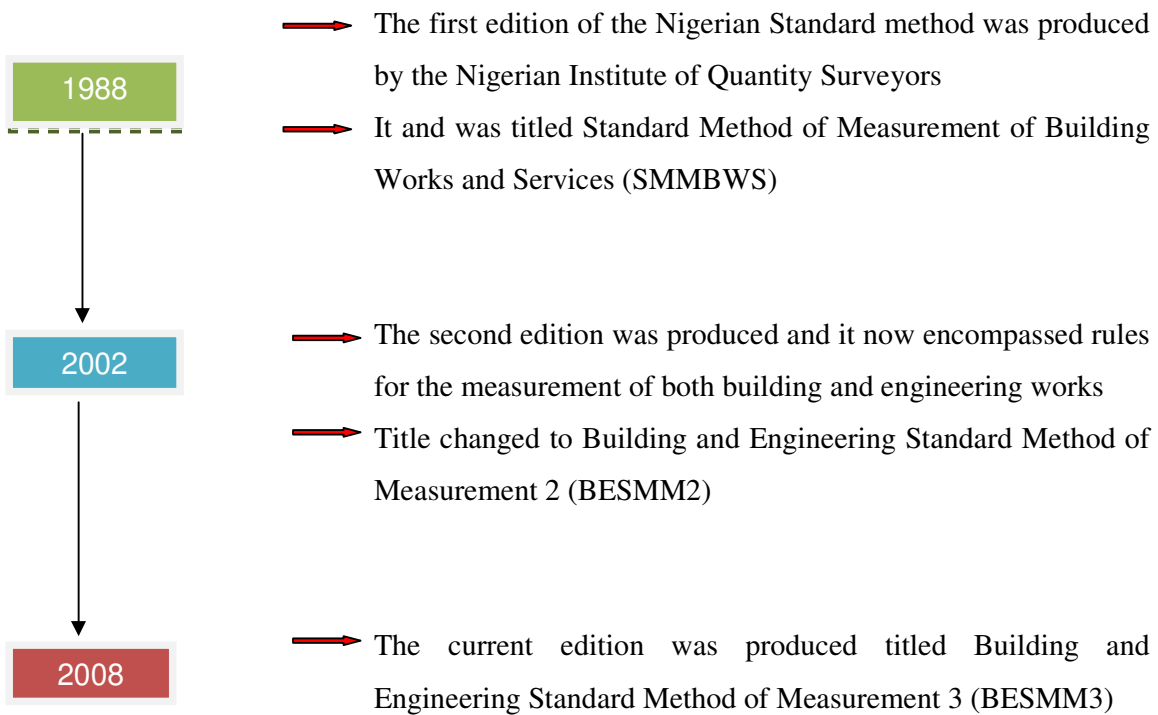

## 1.5 Recent Developments in Quantity Surveying

The practice of the profession of quantity surveying has evolved dramatically starting from the 1970s from that of measurement and valuation to cover much wider areas of expertise in the procuring and management of various types of construction projects. This evolution has come about as a result of changes in:

- Construction markets
- Construction industry
- Clients' needs
- Professions
- Advent of ICT

Today the quantity surveyor is the financial consultant to the construction industry and more, providing services ranging from:

- Cost management
- Life cycle costing
- Project management
- Construction management
- Procurement
- Value management
- Facilities management, etc

## **1.6 Duties of the Quantity Surveyor**

### **1. Preliminary Cost Advice**

The quantity surveyor gives practical advice on:

- The likely cost of the scheme – however complicated or unusual it may be.
- The comparative costs of alternative layouts, materials, components and methods of construction.
- The likely duration of project.
- The likely cost of future maintenance and operating costs.

The quantity surveyor can, from the client's brief, prepare a realistic budget and a cost plan showing the distribution of costs over the various elements.

### **2. Cost Planning**

Cost planning is a specialist technique used by quantity surveyor's, which aims to help all members of the design team to arrive jointly at practical and efficient designs for the project and to keep within the budget. Once a realistic estimate is set from the cost plan, constant monitoring reduces the risk of overspending by noting problem areas at an early stage and applying prompt corrective action.

### **3. Contractual Methods**

The quantity surveyor can advise on the best type of tendering and the best form of contract that will best suit a specific project. The quantity surveyor prepares the documents for obtaining the tenders and arranging the contract.

### **4. Bill of Quantities**

Competitive tendering remains a common basis for selection of contractor and bills of quantities are fundamental to the process. Bills translate the drawings into a document listing in detail all the component parts required for a project so that each contractor can calculate tender prices on exactly the same basis as his competitors.

During construction, the bill forms the basis for preparing interim valuations, pricing of variations and effective cost control.

### **5. Choice of contractor**

The quantity surveyor analyses tenders and makes recommendations to the client for contractor selection after taking into consideration other factors such as the contractors reputation and past performance.

### **6. Contract Administration**

The quantity surveyor acts with the architect or engineer to ensure that the financial provisions of the contract are properly interpreted and applied so that the client's financial interest is safeguarded and that the builder is paid the proper price for the work.

He also exercises control during construction so that the cost is not exceeded without authority.

### **7. Valuation of construction work**

The quantity surveyor prepares interim valuations, values variations and prepares financial statements during construction. He will also settle the final accounts at project completion. He may also prepare statements of expenditure for tax or accounting purposes and assess the project's replacement value for insurance purposes.

Other services of the quantity surveyor include:

## **8. Construction management**

Construction management uses latest management techniques and other applications of programming, network analysis, risk analysis, cash flow forecasting, budgeting and other control mechanisms.

## **9. Building maintenance management**

Building maintenance management involves planning, programming, controlling and costing of maintenance and repair work.

## **10. Dilapidations**

The quantity surveyor prepares schedule of conditions at the beginning of a tenancy or lease and a schedule of dilapidations at the end giving details of an outgoing tenant's liability.

## **11. Arbitration**

This is a formal process for settling disputes

## **12. Facilities management**

This involves all aspects of providing, operating, maintaining, developing and improving facilities which are property where people are accommodated and work.

## **13. Contractor Organisations**

The quantity surveyor may work in a contractor's organisation.

The main function of the contractor's quantity surveyor is to secure maximum payment for work done by the contractor at the earliest possible time to avoid cash flow problems and to maximise profits. These however have to be done within the provisions of the contract. The contractor cannot receive more than he is entitled to by the contract.

In contrast with the consultant quantity surveyor who claims impartiality between the client and the contractor, the contractor's quantity surveyor will be representing his employer's interests alone. Wise contractors therefore always employ quantity surveyors to look after their interests and in particular rely on them in the most controversial contractual areas.

The quantity surveyor working in a contractor's organisation will therefore carry out the following functions among others:

- For design and build contracts or civil engineering contracts, the quantity surveyor works with other professionals in the contractor's organisation to produce initial plans, drawings and estimates for the project and helps to calculate the most economical way to do the job.
- Prepares bills of quantities from which an estimation of the cost of a project can be drawn up by the contractor
- Assessing the "quantity" of labour, materials and equipment required to complete the project
- Follow the progress of the work to ensure that it is completed within budget
- Represents the contractor when interim valuations and final accounts are prepared
- Ensure that they receive the correct payment at the appropriate time for the work done on site.
- Estimating and negotiation of new contracts.
- Site measurements for internal and external valuations, final accounts, cost and bonusing, sub-contract payments and final accounts.
- Domestic subcontractor arrangements and accounts.
- Interpreting and progressing contractual issues and settlement of disputes and claims
- Prepare network analysis
- Prepare cash flow forecasts
- Assess cost of alternative designs of temporary works (preliminary items).
- Scheduling and monitoring of materials
- Plant control
- Reporting to management usually on a monthly basis on the overall financial state of the contract giving comparisons of actual cost with the corresponding internal values for the various cost centres and sub-trades.

## **WEEK 2: THE ROLE OF VARIOUS PROFESSIONALS IN THE CONSTRUCTION PROCESS**

### **2.1 The Quantity Surveyor**

The quantity surveyor is essentially an expert on construction cost and construction contracts whose prime task is to ensure that the project is kept within budget and that the client gets value for money. Although the quantity surveyor is employed by the client and is part of the architect's team, he must have a close relationship with the contractor during construction. He must ensure that in his valuations of payments due to the contractor, he remains impartial to both the client and the contractor and so produce harmony in his role as project accountant.

#### **2.1.1 Pre-contract stage**

The quantity surveyor:

- Gives preliminary cost advice
- Prepares cost plans
- Advises on contractual methods
- Prepares bills of quantities and other tender documents
- Analyses tenders and makes recommendations for contractor selection.

#### **2.1.2 Post-contract period**

- The quantity surveyor works with the architect or engineer to ensure that the financial provisions of the contract are properly interpreted and applied so that the client's financial interest is safeguarded and that cost is not exceeded without authority.
- He prepares interim valuations
- Values variations
- Evaluates all financial claims made by the contractor who is allowed to be present at such times so that agreement is ensured and disputes are avoided
- He also prepares financial statements that keep the client informed as to the running cost of the project.

### **2.1.4 Completion**

- He prepares the final account, again, with the assistance of and in agreement with the contractor.

## **2.2 The Architect**

The architect is regarded as the leader of the building team. However, project managers and other professionals are currently taking over this traditional role. He often receives the commission to design and supervise the construction of the building.

The complexities of modern construction require specialised knowledge, which no architect can provide. He therefore requires the assistance of specialists such as structural engineers to design the structural frame, mechanical engineers to design the M&E services and quantity surveyors to advice on cost and contractual aspects. He will also need advice on ground investigations, landscaping etc.

### **2.2.1 Pre-contract stage**

- He determines the client's requirements for a project, which is known as 'the client's brief'. If the client is unsure of what he wants, the architect can help in formulating this brief.
- Prepares the preliminary designs based on the brief with inputs from quantity surveyors on comparative costs of alternative design proposals and from consulting structural and service engineers on aspects of complex buildings.
- After approval from the client, he produces detailed architectural designs while the engineers produce detailed structural and service designs and the quantity surveyor produces a cost plan based on which he 'cost checks' to keep costs within client's budget.
- Prepares working drawings
- Decides which aspects of the work are to be carried out by nominated subcontractors and suppliers.



When design is completed:

- He obtains all necessary planning approvals
- Calls for tenders from suitable contractors either based on a bill of quantities or other contractual arrangement.
- He receives the tenders and advises the client on selection of contractor usually based on quantity surveyor's recommendation.

### **2.2.2 Post-contract stage**

During construction, the architect:

- Supervises the work, ensuring that the contractor keeps to the design and specification
- Chairs site meetings, which are held regularly on site where problems and difficulties are discussed and resolved.
- Issues instructions to the contractor in relation to the work execution and any variations required.
- Certifies stage payments to the contractor
- Keeps the client informed of progress on site.

### **2.2.3 Completion**

At the end of the project the architect issues:

- The certificate of practical completion
- The certificate of making good defects usually six months after practical completion
- The final certificate not later than two months after the end of the defects liability period.

## **2.3 The Structural, Services & Building Engineers**

On large complex building projects the architect will recommend to the client the employment or appointment of consulting engineers, usually specialist in structural work and mechanical and electrical services.

### **2.3.1 Pre-contract stage**

- The engineer prepares designs and specifications within the scope of their specialist fields advising the architect on the 'buildability' of his concepts. For instance, the structural or building engineer must ensure structural stability with economy in mind and avoidance of obstruction by structural members and also assist in producing a logical and systematic construction process.
- He may be required to obtain, check and recommend quotations from specialist subcontractors in his speciality area.

### **2.3.2 Post-contract**

- During construction, the consulting engineers assist the architect by supervising their specialist area of the work, modifying or re-designing work as may become necessary.

## **2.4 The Civil Engineer**

These are specialists in civil engineering design and construction. In civil engineering contracts they assume the leadership role in the design and construction team. Like architects in building contracts they may require the inputs of other consultants, such as architects, quantity surveyors, service engineers etc.

## **2.5 Professional Bodies and Regulatory Bodies**

### **2.5.1 Who is a professional?**

A professional is an individual who engages in a field of endeavour requiring specialised education, knowledge and skills and who is a member of a self-regulatory body having legislated authority to regulate its members when carrying out activities within a specified field of endeavour.

The professional holds himself or herself out as an expert in a specified field. The person must have the training, skills and experience to back up such a claim.

### 2.5.2 Professional and Regulatory Bodies

Professionals usually come together to form associations to protect members and advance their interests. Governments on the other hand seek to regulate professions in a bid to protect members of the public in relation to the activities of the professionals.

In some countries, the government allows the professional groups self-regulation whereas in others, the government sets up a government agency that has the responsibility of regulating the practice of the profession in that country.

COUNTRY	PROFESSIONAL BODY	REGULATORY BODY
United Kingdom	Royal Institution of Chartered Surveyors (RICS)	Royal Institution of Chartered Surveyors (RICS)
Hong Kong	Hong Kong Institute of Surveyors (HKIS)	Surveyors' Registration Board, Hong Kong
Malaysia	Institution of Surveyors Malaysia (ISM)	Board of Quantity Surveyors Malaysia
Singapore	Singapore Institute of Surveyors' and Valuers (SISV)	
Australia	Australian Institute of Quantity Surveyors (AIQS)	
South Africa	Association of South African Quantity Surveyors (ASAQS)	
Kenya	The Architectural Association of Kenya, Chapter of Quantity Surveyors	Board of Registration of Architects and Surveyors in Kenya
Nigeria	Nigerian Institute of Quantity Surveyors (NIQS)	Quantity Surveyors' Registration Board Of Nigeria (QSRBN)

### **2.5.3 The Nigerian Institute of Quantity Surveyors (NIQS)**

The Nigerian Institute of Quantity Surveyors was founded in 1969 by Nigerians who had trained, qualified and practised quantity surveying in the United Kingdom but who returned to Nigeria and felt the need to develop the profession in Nigeria.

The regulated and other Provisions) Act of 1978 recognised quantity surveying as one of the scheduled professions. Decree No. 31 of 1986 gave legal backing and recognition to the quantity surveying profession and also established the Quantity Surveyors Registration Board of Nigeria (QSRBN) to regulate the profession.

The vision of the NIQS is “To be the profession in Nigeria responsible for total cost and procurement management, for the achievement of client’s objectives in all types of capital projects and developments, from conception to commissioning and maintenance, in all sectors of the economy, for the attainment of sustainable national development and goals.”

The aims and objectives of the institute are:

- (a) To promote the science and practice of the quantity surveying profession in all its ramifications.
- (b) To provide a platform or forum for meeting and discussing matters of mutual interest to quantity surveyors in Nigeria and to preserve and further the interest of quantity surveyors.
- (c) To promote and stimulate the improvement of the technical and general knowledge of persons engaged in the profession of quantity surveying.
- (d) To organise continuing education and professional training of those seeking to become professional quantity surveyors and assist and procure its members to be registered by the QSRBN.
- (e) To undertake research study and to collate information from any quantity surveying bodies from any part of the world on the latest developments and technologies in the practice of quantity surveying and to make available such information to its members.

- (f) To cooperate with the QSRBN in training of quantity surveyors and regulating and controlling the practice of quantity surveying in Nigeria.
- (g) Generally to disseminate information and promote understanding of quantity surveying among members of the public and to cooperate with other professional bodies in Nigeria.
- (h) The maintenance of the highest standards of discipline and professional conduct.

The services offered by the quantity surveyor include:

- |   |  |
|---|--|
| (a) Feasibility studies of capital projects           | (h) Facilities management                            |
| (b) Cost modelling                                    | (i) Direct labour project procurement and management |
| (c) Contract documentation and procurement            | (j) Arbitration                                      |
| (d) Contract administration and management            | (k) Expert witness                                   |
| (e) Monitoring of capital projects                    | (l) Fire insurance assessment                        |
| (f) Preparation of cost reports, pricing of bills etc | (m) Dilapidation                                     |
| (g) Project management                                |  |

Other Professional and Regulatory Bodies in the Nigerian Construction Industry

#### **2.5.4 The Nigerian Institute of Building (NIOB)**

The NIOB was founded in 1967 as the first overseas centre of the Chartered, Institute of Building (CIOB), UK. The NIOB gained autonomy from CIOB in May 1970 and gained its statutory backing in 1989 by the Builders' (Registration etc) Decree No. 45 of the Federal Govt. of Nigeria.

The vision of the NIOB is to provide Nigeria with the profession that will be responsible for the complete construction of new buildings, maintenance of existing buildings and building production management utilising high standards of practice and provide modern and appropriate construction techniques with more emphasis on improved training, safety, quality and value management for the benefit of the fatherland.

### **2.5.5 Council of Registered Builders of Nigeria (CORBON)**

CORBON was established by Builders' (Registration etc.) Decree No. 45 of 1989 to control and regulate the practice of the Building Technology profession in all its aspects and ramifications.

Statutorily, a professional builder cannot practice the profession in Nigeria unless he/she is registered with CORBON and remains registered throughout his/her professional career.

### **2.5.6 The Nigerian Institute of Estate Surveyors and Valuers (NIESV)**

NIESV was founded in 1969 and was registered as a non-profit corporate body under the Land (Perpetual Succession) Act of 1924. It gained formal government recognition in 1975 in the promulgation of the Estate Surveyors and Valuers' (Registration etc.) Decree Number 24 of 1975. This decree established the Estate Surveyors and Valuers' Registration Board of Nigeria, ESVARBON, as a corporate body empowered to regulate the profession of Estate Surveying and Valuation in Nigeria.

### **2.5.7 The Nigerian Society of Engineers (NSE)**

The NSE was founded in 1958 and is the national umbrella organisation for the engineering professions in Nigeria. Engineers Registration Decree No. 55 of 1970 established Council for the regulation of Engineering in Nigeria (COREN). All the disciplines of the profession as currently practiced in Nigeria are duly catered for. Some of the disciplines are organised as divisions of the society to enhance individual career development.

Thirteen divisions have been duly recognised:

- Aeronautical
- Agricultural
- Chemical
- Civil
- Electrical

- Environmental
- Geotechnical
- Industrial
- Mechanical
- Metallurgical
- Petroleum
- Structural
  
- Association of Professional Women Engineers in Nigeria (APWEN)

The objective NSE is to promote the advancement of engineering education, research and practice in all its ramifications. This is with a view to maintaining and enhancing the professional capabilities of its members so as to better equip them to fulfil the needs of the profession for the good of the public and the nation.

### **2.5.8 The Royal Institution of Chartered Surveyors**

RICS can its history right back to 1792 when the Surveyors Club was formed. The foundations of the current modern organisation however started to take shape when 20 surveyors met at Westminster Palace Hotel in London, UK under the Chairmanship of John Clutton. He was later elected the first president of the Institution of Surveyors.

The Institution of surveyors later became the Royal Institution of Chartered Surveyors (RICS) and has evolved into the pre-eminent organisation of its kind in the world. Today the RICS remains the premier institution for quantity surveyors in the world. In terms of construction professional bodies in the UK, the RICS is by far the largest and the most influential with a total membership of over 100,000.

The key requirements expected from the RICS are:

- Improving education and entry level to respond to challenges likely to be met by individuals and firms
- Change from protectionism to facilitator

- Provide leadership in a fragmented construction industry
- Accept that it is the commercial world that is the leading edge but use its position and authority to influence and create and spot trends
- Reflect the need for individuals to remain champions of property and fairness and uphold the charter
- Constantly upgrade professional skills, business skills and knowledge to a level which is envied by other professionals
- Promote the benefits of employing a chartered surveyor so that the currency value of belonging to the RICS is as high as possible
- Improve communications and develop the single profession culture among its members



## WEEK 3: THE STANDARD METHOD OF MEASUREMENT

### 3.1 The Standard Method of Measurement

#### Definition

The standard method of measurement is a document that sets out the rules for the measurement and description of construction works.

#### Purpose

Its main purpose is to provide a uniform basis for measuring construction work. When bills of quantities are prepared based on a particular standard method of measurement, all the parties concerned are aware of what is included, assumed or not included. All contractors tendering therefore tender on the same basis and their tenders can easily be evaluated and compared.

### 3.2 Building and Engineering Standard Method of Measurement 3 (BESMM 3)

The BESMM3 is made up of two main parts. The measurement and description rules in each part are grouped under main headings as follows:

#### PART ONE (BUILDINGS AND THE LIKE)

1A	Preliminaries/General Conditions
C	Existing site/Buildings/Services
D	Ground work
E	In situ concrete/Large pre-cast concrete
F	Masonry
G	Structural carcassing metal/timber
H	Cladding/Covering
J	Waterproofing
K	Linings/Sheathing/Dry Partitioning

L	Windows/Doors/Stairs
M	Surface finishes
N	Furniture/Equipment
P	Building fabric sundries
Q	Paving/Planting/Fencing/Site furniture
R	Disposal systems
X	Transport systems
Y	Mechanical and electrical services measurement

**PART TWO (CIVIL, INDUSTRIAL ENGINEERING WORKS AND THE LIKE)**

2A	General items
C	Demolition and site clearance
D	Ground work
E	In situ concrete/Large pre-cast concrete
G	Metalwork and timberwork
Q	Paving – Highways
X	Transport systems

The section preceding the two chapters contains general rules guiding the use of the standard method. These rules need to be properly understood by the student before commencing actual measurement and will therefore be treated studied in detail in for the next three weeks.

For this course we shall be treating the general rules covering the measurement and description of building works only.

## **General Rules Introduction**

The Bill of Quantities (BOQ) should contain all the items of cost required to complete a construction project. The bill should therefore fully describe and accurately represent the quantity and quality of the works to be carried out. Carefully following the rules prescribed in the Standard Method of Measurement should ensure this.

The use of the SMM will be studied under the following headings:

- ✓ Tabulated Rules
- ✓ Quantities
- ✓ Descriptions
- ✓ Drawn Information
- ✓ Fixing, base and background
- ✓ Procedure when inadequate information is provided
- ✓ Symbols and abbreviations
- ✓ Cross referencing

## **Tabulated Rules**

The rules of the BESMM3 are set out in tables. Rules covering each work group or section are set out under three headings:

- ✓ Information to be provided
- ✓ Classification tables
- ✓ Supplementary rules

The horizontal lines divide the classification tables and supplementary rules into zones to which different rules apply. Fig 1 shows a typical page from the BESMM3.

## C90 Alterations – spot Items

INFORMATION PROVIDED				MEASUREMENT RULES	DEFINITION RULES	COVERAGE RULES	SUPPLEMENTARY INFORMATION
<p>P1 The following information is shown either on location drawings under 1A Preliminaries/General conditions or on further drawings which accompany the bills of quantities: (a) the scope and location of the work relative to the existing layout indicating the existing structure</p>				<p>M1 The rules within this section apply to works in existing buildings as defined in the General rules</p> <p>M2 any operation to existing buildings involving removal of existing materials (other than for bonding purposes or renewal) is measured within this Section</p>	<p>D1 Materials arising from alterations – spot items are the property of the Contractor unless otherwise stated</p> <p>D2 Location is stated relative to the existing building</p>	<p>C1 Shoring and scaffolding incidental to the work and making good all work disturbed is deemed to be included within each item</p> <p>C2 Alterations – spot items are deemed to include: (a) disposal of the materials other than those remaining the property of the Employer or those for re-use (b) work incidental to alterations – spot items which is at the discretion of the Contractor (c) all new fixing or joining materials required</p>	<p>S1 Method of operation, where by specific means</p> <p>S2 Setting aside and storing materials remaining the property of the Employer or those for re-use</p> <p>S3 Employer's restrictions on methods of disposal of materials</p> <p>S4 Employer's restrictions on methods of shoring and scaffolding to be used</p>
CLASSIFICATION TABLE							
1 Removing components, fittings and fixtures	1. Details sufficient for identification stated		Item	1. Making good structures			
2. Removing plumbing and engineering installations	2. Dimensioned description sufficient for identification including type and thickness of existing building			2. Extending and making good finishes			
3. Removing finishing				3. Inserting new work, details stated			
4. Removing coverings				4. Toxic/Hazardous materials, type stated			
5. Cutting openings or recesses							
6. Cutting back projections							
7. Cutting to reduce thickness							
8. filling openings							
9. Temporary roads	1. Dimensioned description		tem	1 Providing and erecting			
10 Temporary screens				2. maintaining, duration state			

**Fig 1**

## Information to be provided

This section ensures that details about the work at hand which the tenderer requires to make accurate estimates are provided either in location drawings, bill diagrams, specifications or preambles as the case may be.

E.g. E05 In-situ concrete states that the relative position of concrete members, size of members, thickness of slabs and permissible loads in relation to casting time must be clearly shown on location drawings or bill diagrams.

## Classification Tables

This section has five columns. The fourth column from the left which contains units of measurement is usually not referred to when cross-referencing. For this reason, the classification table is in some texts said to have four columns.

- ✓ **Column 1** lists work items or processes commonly found in construction works
- ✓ **Column 2** contains subdivisions of the items in column 1
- ✓ **Column 3** is even more specific as it gives a further breakdown of the individual items contained in column 2
- ✓ Unit of measurement column states the unit of measurement appropriate for each item or unit of work
- ✓ **Column 4** contains more descriptive features that are meant to enhance the quality of the descriptions of work built up from columns 1, 2 & 3

In building up a description for an item, one descriptive feature is taken from each of the first three columns and as many as are applicable from the fourth column.

## Supplementary Rules

The section on supplementary rules is made up of a further four columns namely:

- ✓ Measurement rules
- ✓ Definition rules
- ✓ Coverage rules
- ✓ Supplementary information

These rules are meant to guide the user of the SMM to properly measure the physical quantities and to compose and phrase the work item descriptions appropriately.

**Column 5 - Measurement Rules**

These set out when work is to be measured and how the quantities are to be calculated. It states for instance the voids in quantities that are to be deducted and those to be ignored, when to measure an item separately or when to treat as part of some other item, etc.

**Column 6 - Definition rules**

These define the extent and limits of the work represented by a word or expression used in the rules and in the bills prepared in accordance with the rules. For instance the expression “slabs” in relation to in-situ concrete would include the slab itself and any beams attached to it and any column drop heads also attached to it.

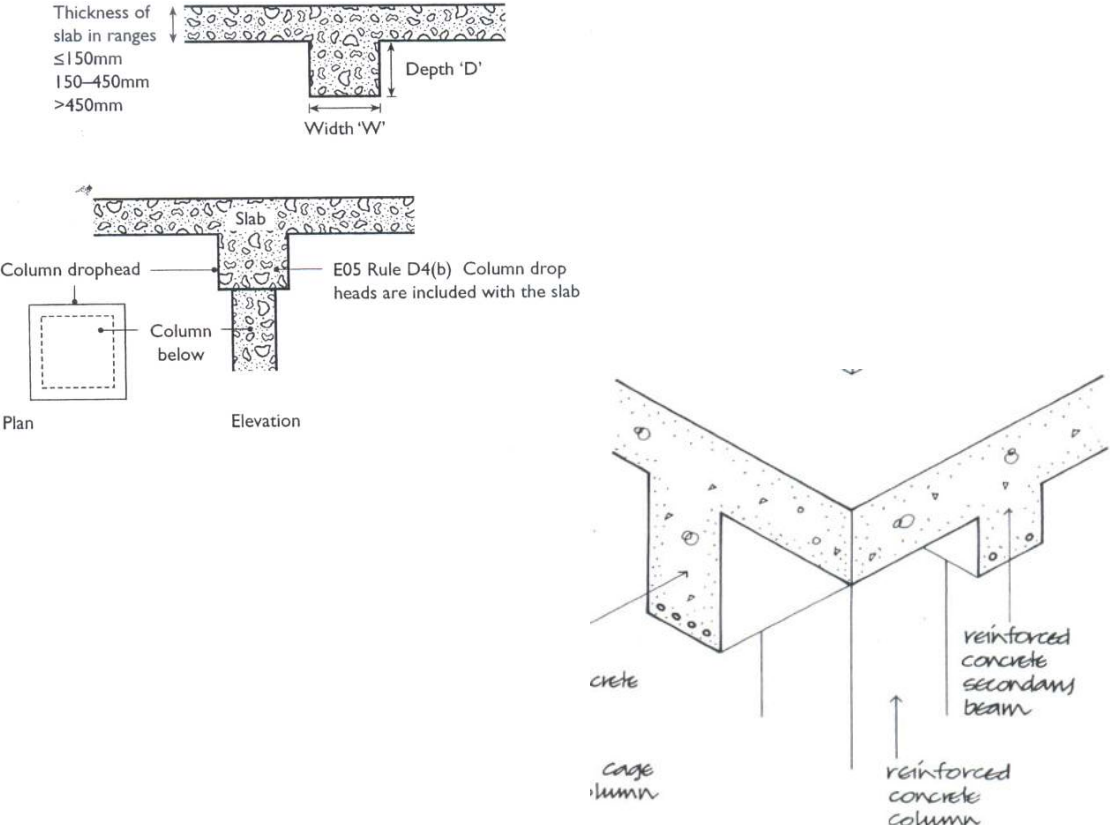

Suspended slab with attached beam & suspended slab with column drop heads

### **Column 7 – Coverage Rules**

These draw attention to incidental items which are deemed to be included or excluded from the item of work being measured. For instance, coverage rule C1 on page 50 states that bar reinforcement is deemed to include hooks, tying wire, spacers and chairs. This means that the contractor in estimating his cost for bar reinforcement should include the cost of any hooks, tying wires, spacers and chairs that he may require for that item of work. These items will not be measured separately or mentioned elsewhere in the bill.

### **Column 8 – Supplementary rules**

These rules govern the information to be given in addition to the information given in accordance with the classification rules. It may contain directives to measure an item separately as a different work item. For instance, additional information is required by the supplementary rules in relation to in-situ concrete suspended slabs on the kind and quality of materials to be used and their mix ratios.

## WEEK 5: BESMM3 GENERAL RULES I

### 4.1 Quantities

Quantities of work are taken net, that is, as they will be when fixed in position in the building unless the rules state otherwise. Dimensions used in calculating quantities are taken to the nearest 10mm. In other words, measurements are taken to two places of decimal when calculating quantities.

When calculations have been completed, quantities are entered into the bills as whole unit with decimal points rounded up to the nearest whole number. The exceptions are:

- Quantities measured in tonnes which are given to two places of decimal
- Quantities that are less than one unit which are always rounded up to one unit

### 4.2 Descriptions

Each measured item consists of a quantity and a description. As a general rule, where an item is measured:

Volumetric/m <sup>3</sup>	No dimensions are required in the description since the three dimensions of the item are used in calculating the volume.
Superficial/m <sup>2</sup>	Two dimensions are used in calculating the area, the third dimension should be stated in the description
Linear/m	One dimension is used for the quantity, the other two dimensions should be stated in the description
Enumerated/Nr or No.	None of the dimensions are used in the quantity column, therefore all three dimensions should be stated in the description



### 4.3 Framing Work Item descriptions

In building up a description for an item, one descriptive feature is taken from each of the first three columns and as many as are applicable from the fourth column. Headings of groups of items in the SMM are read as part of the description.

#### Example 1:

Work item: Suspended in-situ concrete slab

Group heading: In situ concrete

Classification table:

Column 1: Rule 5 - Slabs

Column 2: Rule 2 – Thickness 150 – 450mm

Column 3: Non of the rules apply

Column 4: Rule 1 – Reinforced

Supplementary information:

Column 8: Rule 1 – mix details

Description should then read something like this:

*In-situ concrete (1:2:4)*

*Slabs, thickness 150-450mm, reinforced*

Cross reference or Coding: E05:5.2.0.1

#### Example 2:

Work item: Formwork to soffit of suspended slab

Group heading: Formwork for in-situ concrete

Classification table:

Column 1: Rule 8 – Soffits of slabs

Column 2: Rule 1 – Slab thickness  $\leq$  200mm

Column 3: rule 1 - Horizontal

Column 4: Rule 2 – Height to soffit 1.50m – 3.00m

Column 8: Non of the rules apply

Description should then read something like this:

Formwork to in-situ concrete

*Soffit of slabs  $\leq 200\text{mm}$  thick, horizontal, height to soffit 1.50 – 3.00m*

Cross reference or Coding: E20: 8.1.1.2

### **Example 3:**

Work item: Bar reinforcement in suspended slab

Group heading: Reinforcement for in-situ concrete

Classification table:

Column 1: Rule 1 - Bar

Column 2: Rule 1 – Nominal size stated

Column 3: Rule 1 - Straight

Column 4: Rule 1 – Horizontal length 12.00 – 15.00m

Supplementary information:

Column 8: Rule 1 – kind and quality of materials

Description should then read something like this:

Reinforcement to in-situ concrete

*Mild steel bar reinforcement, 16mm diameter, straight horizontal length 12.00-15.00m*

Cross reference or Coding: E30:1.1.1.1

## **4.4 Drawn Information**

The SMM requires that the bills should be read in conjunction with drawings which are provided in the form of location drawings, component drawings, dimensioned diagrams and schedules.

1. Location drawings include:
  - Block plans which identify the site in relation to the town
  - Site plans which show the position of construction in relation to setting out points, access to the site and general site layout
  - Plans, sections and elevations which show the various spaces and location of the principal elements
2. Component drawings show information required for the manufacture and assembly of a component
3. Dimensioned diagrams that show the space and shape of work items which may be used in a bill of quantities in place of a dimensioned description
4. Schedules deemed to be drawings when they provide required information

#### **4.5 Catalogues or standard components**

A precise and unique cross-reference to a catalogue or standard specification can reduce or replace the requirements for an item description or component drawing. For instance, a precise reference to a British standard (BS) or Code of Practice (CP) can take the place of a detailed description for a work item.

#### **4.6 Fixing, base and background**

- Method of fixing is measured and described where necessary
- The SMM rules may require that the nature of each type of base be identified separately where required
- Where it is required that the nature of background to which an item is to be fixed be identified then the type of background shall be stated in the description of the item as follows:
  - (a) Timber which shall also include all building boards such as hardboard, celotex, etc.
  - (b) Masonry which includes concrete, brick, block and stone
  - (c) Metal
  - (d) Metal faced items
  - (e) Vulnerable materials which shall be deemed to include glass, marble, mosaic, tiled finishes and the like

#### **4.7 Procedure when inadequate information is provided**

Where work can be fully defined as to description but the quantity of work cannot be accurately determined, an estimate of the quantity is given and marked as a “provisional quantity”.

Where work cannot be described and the quantities cannot be adequately determined, it shall be given as a “provisional sum”. Provisional sums may be of two types:

##### **Provisional sum for defined work**

This covers work that though not completely designed, the following information is available:

- The nature of the construction or work
- How and where the item of work is fixed in the building
- A quantity which indicates the scope and extent of the work
- Any specific limitations

In such cases, the Contractor is expected to make allowance for the work in his programming, planning and pricing of preliminaries

##### **Provisional sum for undefined work**

This covers work for which none of the above information can be provided. In this case, it is assumed that the contractor has not made any allowance for it in his programming, planning and pricing of preliminaries.

#### **4.8 Symbols and Abbreviations**

During the process of “taking-off” or measurement words entered in the description column are abbreviated to shorten descriptions, save space and also save time. The symbols and abbreviations range from those in general use to those that are specifically used by quantity surveyors.

Those in common use include:

M	Metre
m <sup>2</sup>	Square metre
m <sup>3</sup>	Cubic metre
Mm	Millimetre
Nr or No.	Number
Kg	Kilogram
T	Tonne
H	hour

Specialised abbreviations

a.b.d	As before described
av.	average
Blk	Block
blkwk	Blockwork
c/c	Centres
col.	Column
conc.	Concrete
c.w.	Cold water
ddt	Deduct
dp	Deep
dpc	Damp proof course
ditto/do	As above
e.o.	Extra over
exc.	Excavate

fdn	Foundation
fwk	Formwork
g.l.	Ground level
hwd	Hardwood
Int.	Internal
isol.	Isolated
Jt.	Joint
k.p.s	Knot, prime and stop
matl.	Material
max.	Maximum
m.s.	Mild steel
o/a	Overall
p.c.	Prime cost
reinfd	Reinforced
sprd	Spread
s.s.o	Switched socket outlet
susp.	Suspended
swd	Soft wood
t & g	Tongued and grooved
thk	Thick
vert	Vertical
wdw	Window
wk	Work
wrot	Wrought
wt.	Weight
xtg	existing

## WEEK 5: BESMM3 GENERAL RULES II

### Cross Referencing

Cross referencing or coding of work item descriptions within the classification tables are given in the form:

Work section number	Number from the first column	Number from the second column	Number from the third column	Numbers from the fourth column
---------------------	------------------------------	-------------------------------	------------------------------	--------------------------------

### Example 1:

D20: 2.1.1.0

Excavating and filling

Work section number

Excavating

Column 1, number 2

Topsoil for preservation

Column 2, number 1

Average depth 150mm

Column 3, number 1

Column 4, no relevant entry

		14.85		Excavating topsoil for preservation, average depth 150mm (D20:2.1.1.0)			
		16.45					
		<u>0.15</u>					

### NOTE!

An asterisk (\*) within a cross reference represents all entries in the column in which it appears

A zero (0) within a cross reference represents no entries from the column in which it appears

Cross referencing of descriptions is useful for abstracting and billing using the computer.

### Example 2

D20:2.6.3.1

Excavating and filling

Work section number

Excavating

Column 1, number 2

Trenches, width  $\leq$  0.30m

Column 2, number 6

Maximum depth  $\leq$  2.00m

Column 3, number 3

Commencing 0.45m below ground level

Column 4, number 1

		42.44 0.68 <u>1.75</u>		Excavating trenches, width exceeding 0.30m, maximum depth not exceeding 2.00m, commencing 0.45m below ground level (D20:2.6.3.10)				
--	--	------------------------------	--	---	--	--	--	--



**Example 3**

D20:7.2.1.1

Excavating and filling

Earthwork support

Maximum depth  $\leq 2.00\text{m}$

Distance between opposing faces  $\leq 2.00\text{m}$

Curved

Work section number

Column 1, number 7

Column 2, number 2

Column 3, number 1

Column 4, number 1

	2 / 42.44 <u>1.75</u>		Earthwork support, maximum depth not exceeding 2.00m, distance between opposing faces not exceeding 2.00m, curved (D20:7.2.1.1)				
--	--------------------------	--	---	--	--	--	--

**Example 4**

E05:9.1.2.1

In situ concrete

Work section number

Beams

Column 1, number 9

Isolated

Column 2, number 1

Cross-sectional area 0.03-0.1m<sup>2</sup>

Column 3, number 2

Reinforced

Column 4, number 1

		5.65 0.23 <u>0.30</u>		Reinforced in-situ concrete in isolated beams, 0.03-0.1m <sup>2</sup> cross sectional area (E05:9.1.2.1)				
--	--	-----------------------------	--	--	--	--	--	--

### Example 5

E20:1.1.2.1

Formwork to in situ concrete

Work section number

Sides of foundation

Column 1, number 1

Plain vertical

Column 2, number 1

Height □ 250mm

Column 3, number 2

Left in

Column 4, number 1

		5.65 0.23 <u>0.30</u>		Reinforced in-situ concrete in isolated beams, 0.03-0.1m <sup>2</sup> cross sectional area (E05:9.1.2.1)				
--	--	-----------------------------	--	--	--	--	--	--

### Example 6

E30:4.1.0.0

Reinforcement

Work section number

Fabric

Column 1, number 4

Steel to BS 4483 ref. A193; weighing 3.02 kg/m<sup>2</sup>

Column 2, number 1

Column 3, no entry

Column 4, no entry

		14.50 <u>16.10</u>		Steel fabric reinforcement to BS 4483 ref. A193, weighing 3.02Kg/m <sup>2</sup> (E30:4.1.0.0)				
--	--	-----------------------	--	--	--	--	--	--

**Example 7**

M10:5.1.1.1

Cement: sand screed

Floors

Level and to falls only  $\leq 15^\circ$  from horizontal

50mm thick, one coat

Laid in bays 1.20m x 1.20m

Work section number

Column 1, number 5

Column 2, number 1

Column 3, number 1

Column 4, number 1

	5.65		Cement & sand screed on floors, level and to falls only not exceeding $15^\circ$ from horizontal, 50mm thick, laid in bays average size 1.20m x 1.20m (M10:5.1.1.1)				
	0.23						
	<u>0.30</u>						

## **CLASSROOM EXERCISE**

Identify the relevant clauses in the BESMM3 to measure the following items, frame appropriate descriptions and insert sample dimensions of the appropriate units:

1. Pit excavations for column bases, 2.3m deep
2. Reinforced is-situ concrete isolated columns, 225 x 225mm sectional size
3. 16mm diameter mild steel bar reinforcement to BS 4449 in isolated beams
4. Hardcore filling of broken blocks to make up levels under floors 300mm thick
5. White glazed vitreous china wash hand basin size 460 x 405
6. Testing and commissioning drainage
7. 22 SWG aluminium flashing 545mm wide

## WEEK 6: BESMM3 GENERAL RULES III

### Cross Referencing (Continued)

#### Example 8

F10:1.1.1.2

Brick/block walling

Work section number

Walls

Column 1, number 1

225mm thick

Column 2, number 1

Vertical

Column 3, number 1

Bonded to glass block walling

Column 4, number 2

	55.55 <u>3.00</u>		Walls, 225mm thick, vertical of 450 x 225 x 225mm hollow sandcrete blocks laid in stretcher bond in c.m (1:4) and bonded to glass block walling <p style="text-align: right;">(F10:1.1.1.2)</p>				
--	----------------------	--	--	--	--	--	--

**Example 9**

F10:2.1.1.0

Brick/Block walling

Isolated piers

450mm thick

Vertical

Work section number

Column 1, number 2

Column 2, number 1

Column 3, number 1

Column 4, no entry

32	0.45 <u>2.70</u>		Isolated piers, 450mm thick, vertical of 450 x 225 x 225 solid sandcrete blocks in English bond in c.m (1:4) (F10.2.1.1.0)				
----	---------------------	--	---	--	--	--	--

**Example 10**

G20:9.2.1.1

Carpentry/Timber framing/First fixing

Work section number

Roof members

Column 1, number 9

Pitched

Column 2, number 2

50 x 150mm

Column 3, number 1

Exceeding 6.00m in continuous length

Column 4, number 1

2 /15	<u>6.88</u>		Roof members, pitched, 50 x 150mm sawn hardwood, treated with one coat wood preservative, exceeding 6.00m in continuous lengths, 6.88m long (G20:9.2.1.1)				
----------	-------------	--	--	--	--	--	--



**Example 11**

H72:1.1.0.0

Aluminium strip/sheet coverings/flashings

Roof covering

50° pitch

Work section number

Column 1, number 1

Column 2, number 1

Column 3, no entry

Column 4, no entry

	2 /	27.35 <u>6.90</u>	Roof covering, 50° pitch, 0.7mm thick, 22SWG longspan al. sheet roofing with two corrugations side laps and 150mm end laps, fixed to 50 x 50mm pulims @ 900mm c/c (m/s) with 8mm hook bolts incl seam bolting at 900mm c/c with al. drive screws and neoprene sealer washers to manufacturer's instructions (H72:2.1.0.0)				
--	-----	----------------------	---	--	--	--	--

Example 12

J41:2.1.0.0

Built-up felt roof covering

Roof covering

Pitch 1:40

Work section number

Column 1, number 2

Column 2, number 1

Column 3, no entry

Column 4, no entry

		14.32 <u>7.88</u>		Built up felt roofing to BS 747, NT Paralon bituminous felt in 3 layers with 150mm min. end and side laps, hot bitumen bonded between layers and laid on screeded bed to pitch 1:40 (J41.2.0.0)				
--	--	----------------------	--	--	--	--	--	--

**Example 13**

L10.1.0.1.0

Windows/Roof lights/Screens/Louvres

Work section number

Windows and window frames

Column 1, number 2

Column 2, no entry

Dimensioned diagram Fig 22

Column 3, number 1

Column 4, no entry

	<u>12</u>		Anodised al. sliding window and frame, size 1200 x 1200mm high as reference XYZ Fig 22, factory glazed with 4mm tinted sheet glass, including cutting and pinning lugs to blkwk and conc. (L10:1.0.1.0)				
--	-----------	--	--	--	--	--	--

**Example 14**

L20.1.0.1.0

Doors/Shutters/Hatches  
number

Work section

Doors

Column 1, number 1

Column 2, no entry

Dimensioned diagram Fig 38

Column 3, number 1

Column 4, no entry

		<u>6</u>		44mm Flush door 838 x 1981mm high semi solid core faced both sides with 'mahogany' plywood and lipped all round with 6mm hardwood as diagram Fig. 38 (L20:1.0.1.0)				
--	--	----------	--	---	--	--	--	--

**Example 15**

M60.1.0.1.0

Painting/Clear finishing

General surfaces

Girth > 300mm

Work section number

Column 1, number 1

Column 2, no entry

Column 3, number 1

Column 4, no entry

	6 / 0.84		K.p.s, prepare & apply 2 undercoats and one finishing coat of gloss paint on general hardwood surfaces, exceeding 300mm girth (M60:1.0.1.0)				
	<u>1.98</u>						
	6 / 0.93						
	<u>2.03</u>						

## **CLASSROOM EXERCISE**

Identify the relevant clauses in the BESMM3 to measure the following items, frame appropriate descriptions and insert sample dimensions of the appropriate units:

1. Sawn formwork to isolated beams
2. 12 mm thick cement and sand rendering on walls
3. 3 coats of emulsion paint on rendered walls
4. 300 x 300 x 6mm ceramic tiles on screeded bed
5. 3 coats of gloss paint on metal internal door frames, girth 250mm
6. 25 x 300mm softwood fascia board
7. Forming cavity in hollow walls

## WEEK 7: MEASUREMENT PROCEDURES

### 7.1 Taking-Off

This implies reading off dimensions from drawings and setting them down in a specific order on special paper known as dimension paper and inserting an appropriate description.

#### Standard Dimension Paper

	1.	2.	3.	4.		1.	2.	3.	4.
--	----	----	----	----	--	----	----	----	----

On the left-hand side is a narrow binding margin. The remainder of the sheet is divided into two identical halves each containing three narrow columns and a wider one; the timesing column, the dimension column, the squaring column and the description column respectively. The columns are used as follows:

1. Timesing column is used for multiplying (timesing) the dimensions when necessary, each multiplying factor followed by an oblique stroke. A factor followed by a dot indicates addition instead of multiplication.

	4	3.45		
		7.59		
		<u>0.15</u>		
	<del>2</del>	2.08		
	·	4.44		
1		0.15		

2. Dimension column is used for recording the dimensions in metres and centimetres. Each linear dimension is underlined.

LINEAR

		<u>7.59</u>							
									← Length

A pair of dimensions, one above the other:

**AREA**

		3.45	←	Length
		<u>7.59</u>	←	Width

indicates an area (a superficial item)

A group of three dimensions

**VOLUME**

		3.45	←	Length
		7.59	←	Width
		<u>0.15</u>	←	Depth

indicates a volume ( a cubic item)

A number (without a decimal point)

**NUMBER**

		<u>2</u>		
--	--	----------	--	--

indicates an enumerated item

Note the order of entering dimensions is strictly:

1. Length
  2. Width
  3. Depth/height
- General rules 4.1)

Item indicates an item of cost for which a quantity cannot be calculated. A sum of money is usually estimated and allowed for in the bills.



**ITEM**

		<u>Item</u>		Allow for bringing to site and removing from site all plant required for this work section
--	--	-------------	--	--

3. Squaring column: the resulting areas and volumes inserted in the timesing and dimension columns are subsequently calculated and entered into the squaring column opposite their respective dimensions.

	4	3.45		
		7.59	15.71	
		<u>0.15</u>		
	2	2.08	4.16	
		4.44		
	▪	<u>0.15</u>		
1				

4. Description column: This wide column is for entering descriptions of the measured work.

	4	3.45		Hardcore filling to make up levels under floors, average thickness not exceeding 250mm
		7.59	15.71	
		<u>0.15</u>		
	2	2.08	4.16	
		4.44		
	▪	<u>0.15</u>		
1				

5. Waste column: This is an imaginary column occupying the right hand side of the description columns in which the taker-off inserts any preliminary calculations (waste) which may be necessary in order to arrive at his dimensions.

All preliminary calculations must be shown in waste. They need to be set down accurately and carefully so they can be checked. They should be written either above or below the description not level with it to avoid confusion.

Waste calculation is necessary for each dimension except in the following situations:

- a) When a scaled or figured dimension can be transferred direct from the drawing to the dimension column
- b) When a dimension has been derived from a previous waste calculation
- c) When a dimension has been copied from a previous dimension
- d) In all other instances the preliminary calculation however simple should be shown on waste.

Waste calculation should be done in millimetres or to three places of decimal. Final figures are then rounded off to the nearest 10mm before being transferred to the dimension column.

## 7.2 Descriptions

The first line of each description should start at the same level as its first dimension. Standard or common abbreviations are allowed in taking off but descriptions must be written in full in BOQs.

Descriptions must be concise, brief and free from grammatical errors. Terms used must comply with current technical usage and an estimator must be able to read, understand and price it quickly and accurately.

The following points should be noted:

- Descriptions should not be broken at the bottom of the page or column to continue overleaf
- Do not write 'ditto' at the top of a column as this has no meaning
- Instead, repeat the first phrase in the description followed by "... as before described" or "abd",

Anding-on: Where two descriptions apply to one dimension, they are separated by an & in the centre of the description column. Any number of descriptions may be anded-on in this way but not so as to extend to another column.

		15.67	Plain in-situ conc (1:3:6) abd  &  <u>Ddt</u> Backfill exc. matl. Abd  &  <u>Add</u> Remove excvtd matl. from site
		0.68	
		<u>0.23</u>	
		7.89	
		0.68	
		<u>0.23</u>	
		13.99	
		0.45	
		<u>0.15</u>	

### Deductions

Each item to be deducted requires the description to start with the word Deduct or Ddt (underlined). A description must follow the word Ddt. It should not be written on its own. The next positive description should be preceded with the word Add (underlined) in order to emphasise the change from deductions to additions.

### Bracketing

A bracket should be used wherever:

- (a) More than one dimension applies to a description
- (b) More than one description applies to a dimension

The bracket is written in the description column just next to the squaring column.

Niling

In order to delete, cancelling of dimensions is not allowed. Instead, the word “NIL” is written in the squaring column opposite the offending dimension or dimensions. Arrows are usually used to denote the extent of the deletion.

		32.89		
		0.68		
		<u>0.23</u>		
		15.67		
		0.68		
		<u>0.23</u>		
		7.89		
		0.68		
		<u>0.23</u>		
		13.99		
		0.45		
		<u>0.15</u>		
		25.54		
		0.45		
		<u>0.15</u>		



## Annotations

Annotations are short or abbreviated words written beside waste calculations and dimensions to denote from where the figures have been derived.

Side notes to dimensions require a single bracket on the left hand side only.

Example:

		7.55	} 300 x 300 x 6mm Floor flex tiles on trowelled bed (master BDR ( BDR 1 (BDR 2 (BDR 3 (BDR 4
		<u>5.50</u>	
		4.50	
		<u>5.89</u>	
		4.40	
		<u>3.60</u>	
		4.50	
		<u>3.77</u>	
		4.55	
		<u>3.45</u>	

## **Spacing of dimensions**

All measurements and descriptions should be spaced well apart so that it is quite clear where one begins and the other ends. Moreover it is not unusual for the taker-off to realise an omission and to want to insert it in its proper place. If dimensions are well spaced out, he will be able to squeeze it in, but otherwise he will have to insert it elsewhere and resort to cross-referencing which only confuses things.

## WEEK 8: APPLIED MENSURATION I

### 8.1 Introduction

Determination of quantities for work items in construction work involves calculating geometric quantities such as lengths, areas and volumes from dimensions and angles that are known. Doing this will require a healthy knowledge of the formulae for calculating the perimeters, areas and volumes for various shapes.

These various shapes form the building blocks for most components found in construction work.

For instance, the area of the concrete floor slab below is a combination of rectangles of different sizes.

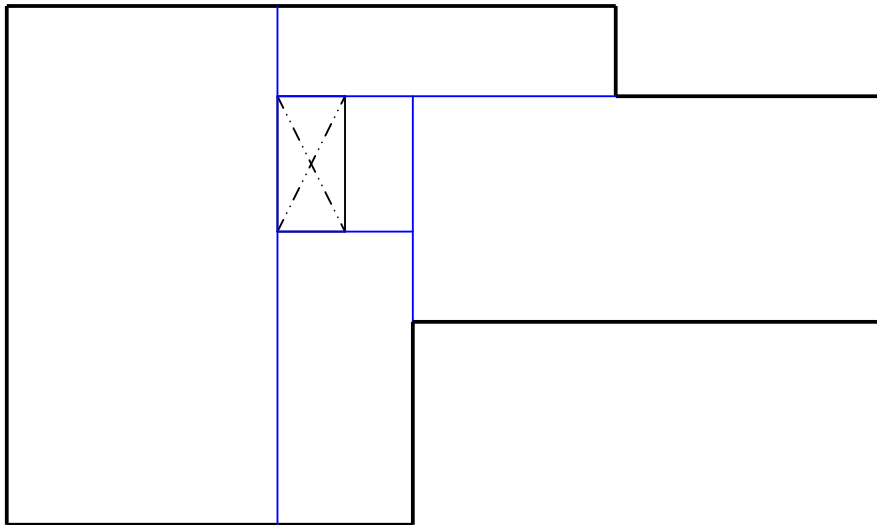

Irregular shaped floor slab with a void

The archway below is made up of a half circle and a rectangle and the gabled wall is made up of a triangle and a rectangle.

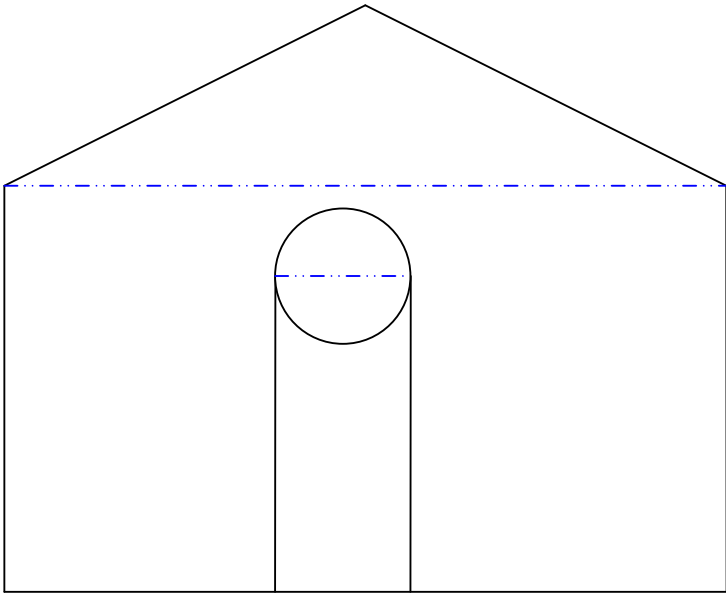

The hipped roof below is made up of two triangles and two rectangles

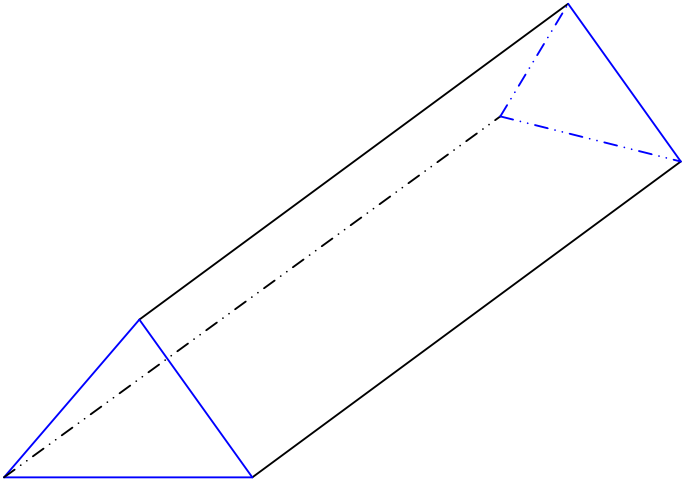

The following are useful formulae for calculating volumes, areas and perimeters of various shapes

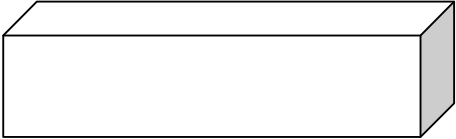
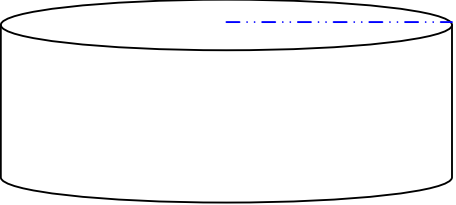
SHAPE	FIGURE	VOLUME	TYPICAL BUILDING COMPONENTS
Rectangular prism		<p>Area of base x height</p> <p>Base is a rectangle, therefore</p> <p>Length x breadth x height</p>	<p>Slabs</p> <p>Beams</p> <p>Columns</p> <p>Trench excavations</p> <p>Pit excavations</p> <p>Basement excavations</p> <p>Filling</p>
Cylinder		<p>Area of base x height</p> <p>Base is a circle, therefore</p> <p><math>\pi \times (\text{radius})^2 \times \text{height}</math></p>	<p>Circular slabs</p> <p>Circular columns</p> <p>Circular pit excavations</p> <p>Circular basements</p> <p>Filling</p>

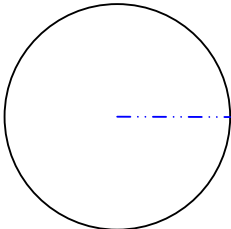
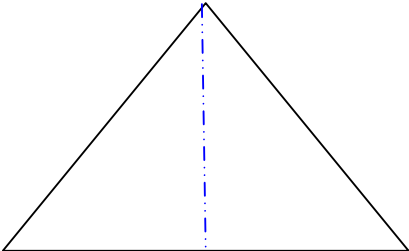

SHAPE	FIGURE	AREA	PERIMETER
Rectangle		Length x breadth	$(\text{Length} + \text{breadth}) \times 2$
Circle		$\pi \times (\text{radius})^2$	$\pi \times \text{radius} \times 2$
Triangle		$\frac{1}{2} \times \text{base} \times \text{height}$	Side A + side B + side C

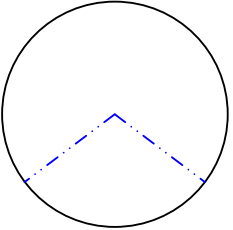
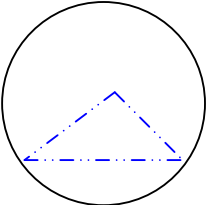
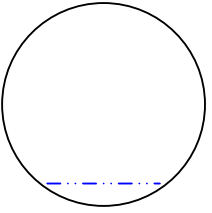
SHAPE	FIGURE	AREA	PERIMETER
Arc of circle			$2 \times \pi \times \text{radius} \times \theta/360^\circ$
Sector of a circle		$\frac{1}{2} \times \text{length of arc} \times \text{radius}$	Length of arc + (radius x 2)
Segment of a circle		Area of sector – Area of triangle	Length of arc + length of chord
Chord			

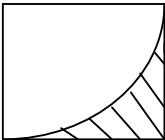
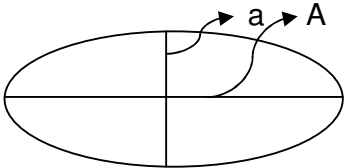
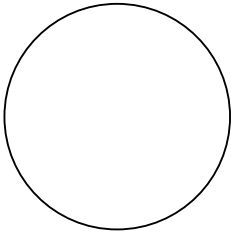
SHAPE	FIGURE	AREA	PERIMETER
Bellmouth		$0.2146 \times \text{radius} \times \text{radius}$	
Ellipse		$0.7854 \times (A \times a)$	
Sphere		$4 \times \pi \times (\text{radius})^2$	

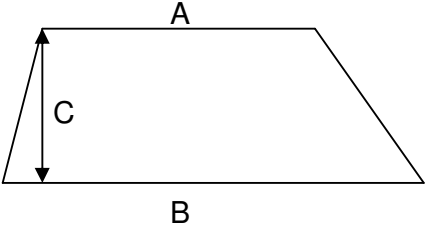
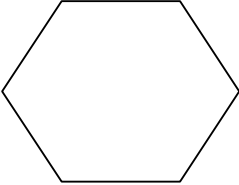
SHAPE	FIGURE	AREA	Perimeter
Trapezoid	 <p>The diagram shows a trapezoid with a shorter top horizontal edge labeled 'A' and a longer bottom horizontal edge labeled 'B'. A vertical line segment with arrows at both ends, labeled 'C', represents the height of the trapezoid.</p>	<p>Height x <math>\frac{1}{2}</math>(base + top)</p> <p><math>C \times \frac{1}{2}(A + B)</math></p>	
Hexagon	 <p>The diagram shows a regular hexagon with six equal sides and six equal interior angles.</p>	<p><math>2.6 \times (\text{side})^2</math></p>	
Octagon		<p><math>4.83 \times (\text{side})^2</math></p>	

## WEEK 9: APPLIED MENSURATION II

### 9.1 Relationship between shapes and Building Measurement

Measurement of a building or item of construction involves calculating lengths, areas or volumes of different shapes and sizes. It may also involve counting or enumerating some types of components. Invariably, most components can be analysed into some common shapes that the formulae are known.

For instance, measuring the volume of excavation for a foundation trench involves calculating the area of a rectangle (cross section of the trench) and multiplying by the length of trench.

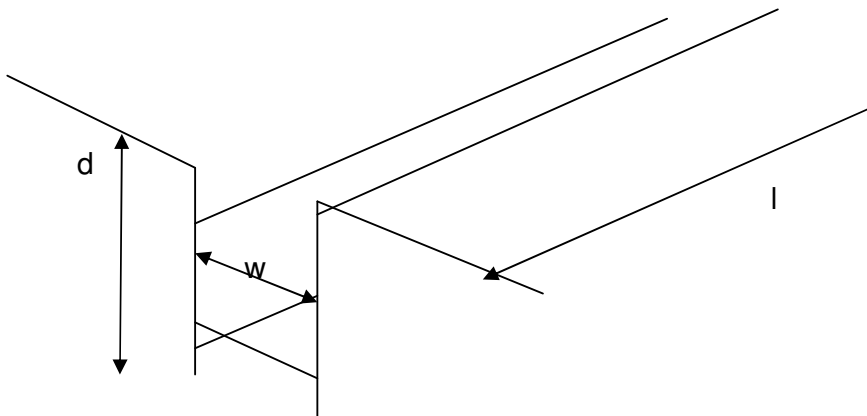

$$\text{Volume} = \text{length (l)} \times \text{width (w)} \times \text{depth (d)}$$

Measuring the volume of concrete in an irregularly shaped floor:

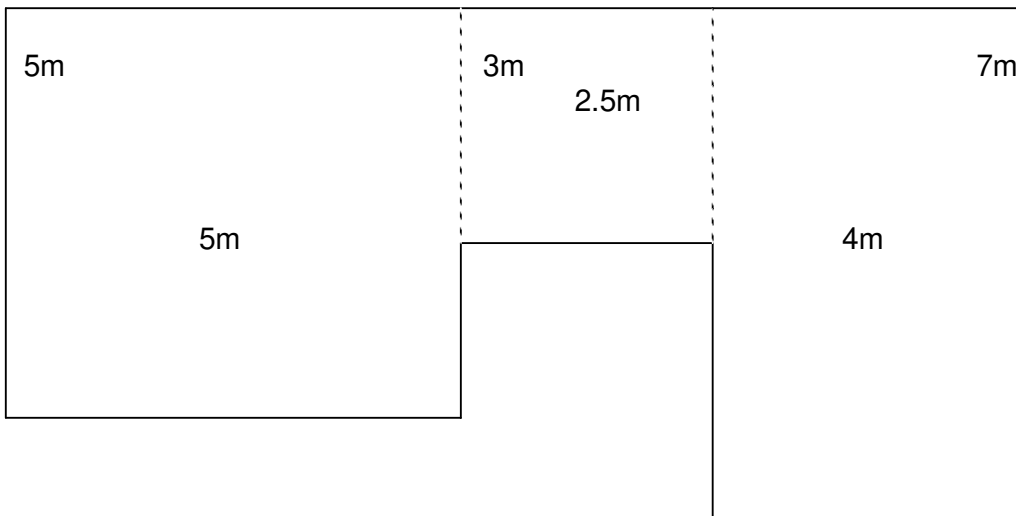

The surface area of the floor would naturally divide into three rectangles. If the thickness of the floor was 150mm (0.15m), then,

$$\text{Volume of concrete} = (5 \times 5 \times 0.15) + (3 \times 2.5 \times 0.15) + (7 \times 4 \times 0.15) \text{ m}^3$$

$$= \underline{13.28\text{m}^3}$$

Setting out the above figures on a dimension sheet will be as follows:

	5.00						
	5.00						
	<u>0.15</u>	3.75					
	3.00						
	2.50						
	<u>0.15</u>	1.13					
	7.00						
	4.00						
	<u>0.15</u>	<u>8.40</u>					
		<u>13.28</u>					

An area of a component of wall would usually be the area of a rectangle, length of wall multiplied by the height. If the wall is a gable wall then it would be rectangle topped by a triangle.

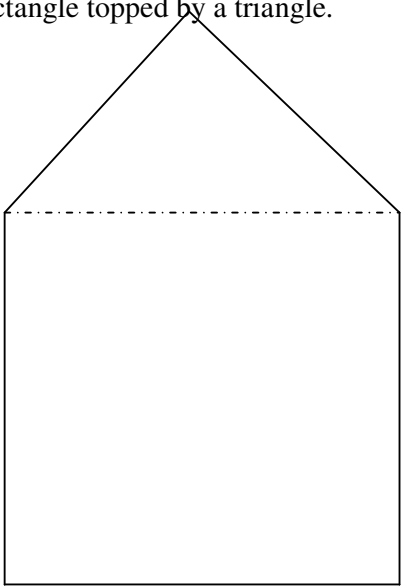
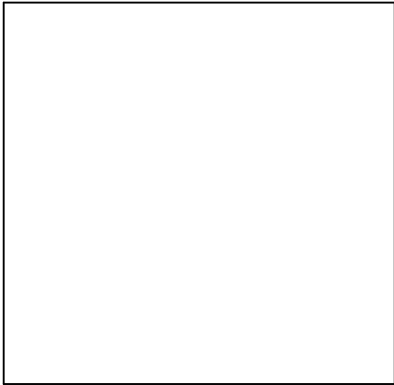

A wall would also usually have openings for windows, doors, arches, fixed lights, etc. The usual thing is to measure the whole wall overall as if there were no openings and then systematically deduct for openings that are rectangles, triangles and circles or parts thereof.

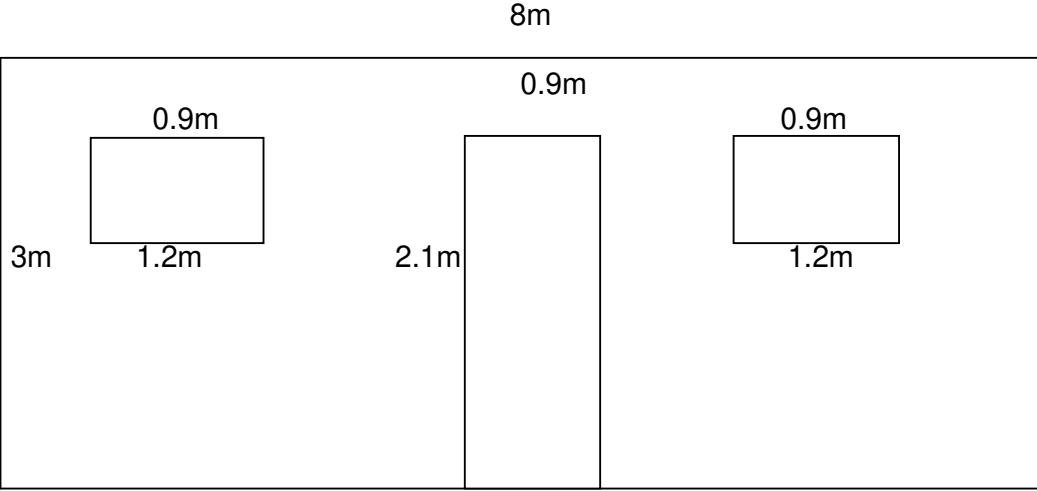

$$\begin{aligned}
 \text{Area of wall} &= (8\text{m} \times 3\text{m}) - \{ (1.2 \times 0.9) + (0.9 \times 2.1) + (1.2 \times 0.9) \} \text{m}^2 \\
 &= 24\text{m}^2 - (1.08 + 1.89 + 1.08) \text{m}^2 \\
 &= 24\text{m}^2 - 4.05\text{m}^2 = 19.95\text{m}^2
 \end{aligned}$$

		8.00		225 mm hollow			
		<u>3.00</u>	<u>24.00</u>	sandcrete block wall in			
				c.m (1:4)			
2	1.20			Ddt			
	<u>0.90</u>	2.16		Ditto			
	0.90						
	<u>2.10</u>	<u>1.89</u>					
		<u>4.05</u>					

Formwork to an isolated concrete column 225 x 225mm sectional size, 3m long. Formwork will go round all four sides.

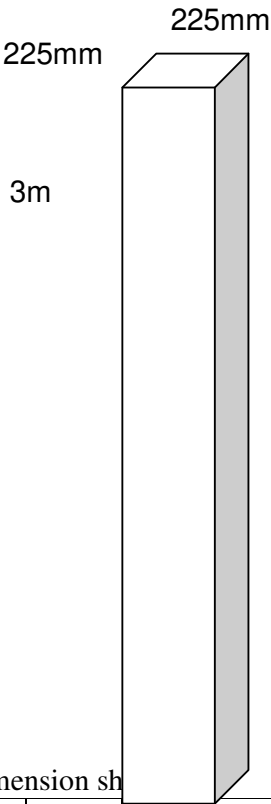

Perimeter of rectangle or square  
 $= 225 + 225 + 225 + 225\text{mm}$   
 OR  $= 225 \times 4\text{mm} = 900\text{mm}$   
 Area of formwork  $= 0.90 \times 3.00\text{m}^2$   
 $= \underline{2.7\text{m}^2}$

On dimension sheet

	4	0.23					
	/	<u>3.00</u>	<u>2.76</u>				



Formwork to attached column 225 x 450 mm sectional size, 3.00m long

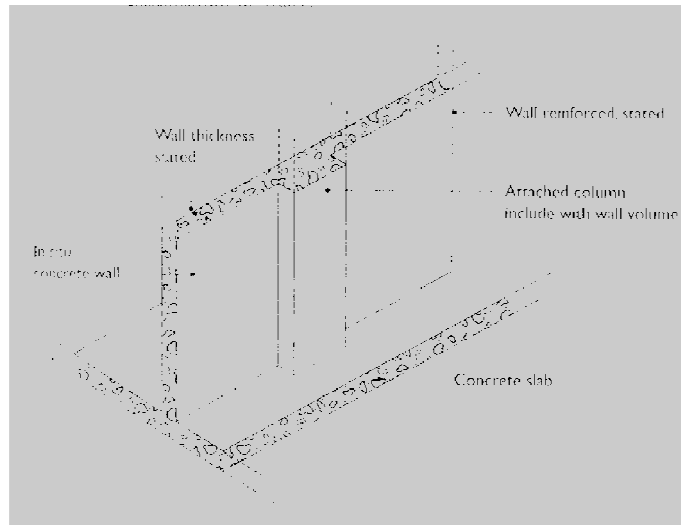

In this case, formwork is only on three faces of the concrete, on the two sides and on the wide face.

Perimeter of rectangle excluding one side = 225 + 450 + 225mm

$$= 0.900\text{m}^2$$

Area of formwork

$$= 3\text{m} \times 0.9\text{m}^2$$

$$= 2.7\text{m}^2$$

On dimension sheets:

				Length 225 450 <u>225</u> <u>900</u>				
	8	/ 0.90 <u>3.00</u>	<u>21.60</u>	Formwork to slabs attached to slabs, 225 x 300mm plain rectangular shape (in 8 Nr)				



Any irregular-shaped area to be measured is usually best divided into triangles, the triangles being measured individually and added to give the area of the whole. A line can be drawn through an irregular or curved boundary in such a way that the area excluded by the line is compensated for by the area that is included by it.

## WEEK 10: CENTRE LINE GIRTH I

### 10.1 Introduction

The perimeter of a shape without thickness is simple to compute arithmetically using the principle of  $(\text{length} + \text{breadth}) \times 2$ . Whilst the simple arithmetic concept is always to be used, the computation often proves to be somewhat complex for most students when a thickness is attributed to the shape as is always the case when the perimeter of a wall or a trench is required to be computed.

To compute the perimeter of a wall, we will need to work out the perimeter of the internal line of the wall and the perimeter of the external line of the wall and then compute the average of the two perimeters. This procedure will turn out to be clumsy if not cumbersome. Hence the need for the systematic computation of centre line as set out in the foregoing examples.

The importance of centre line computation cannot be over-emphasised as the result of the computation will subsequently be found to be useful for the measurement of several items all through the take-off stages.

#### Simple rectangular plan shape

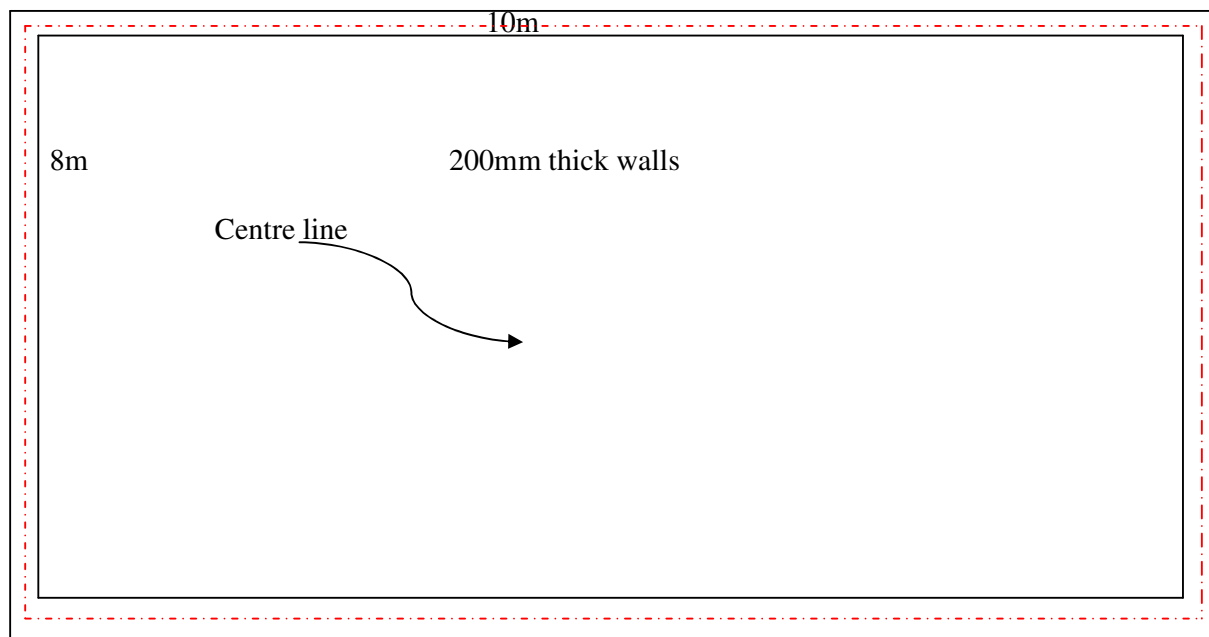



Rectangular plan shape with a recess at corner(s)

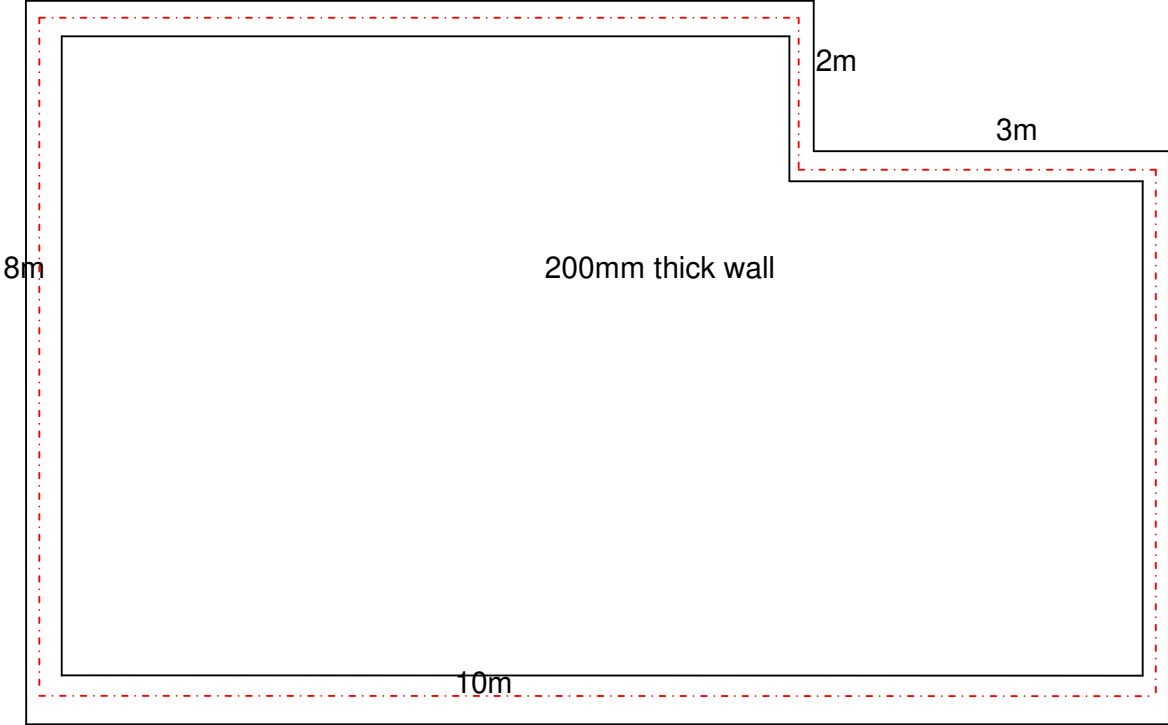



## **CLASS EXERCISE**

Give students a rectangular shape with recesses at two corners (all dimensions given) to work out the centre line for the recessed shape.

## WEEK 11: CENTRE LINE GIRTH II

11.1 Rectangular plan shape with a recess along the wall  
10m

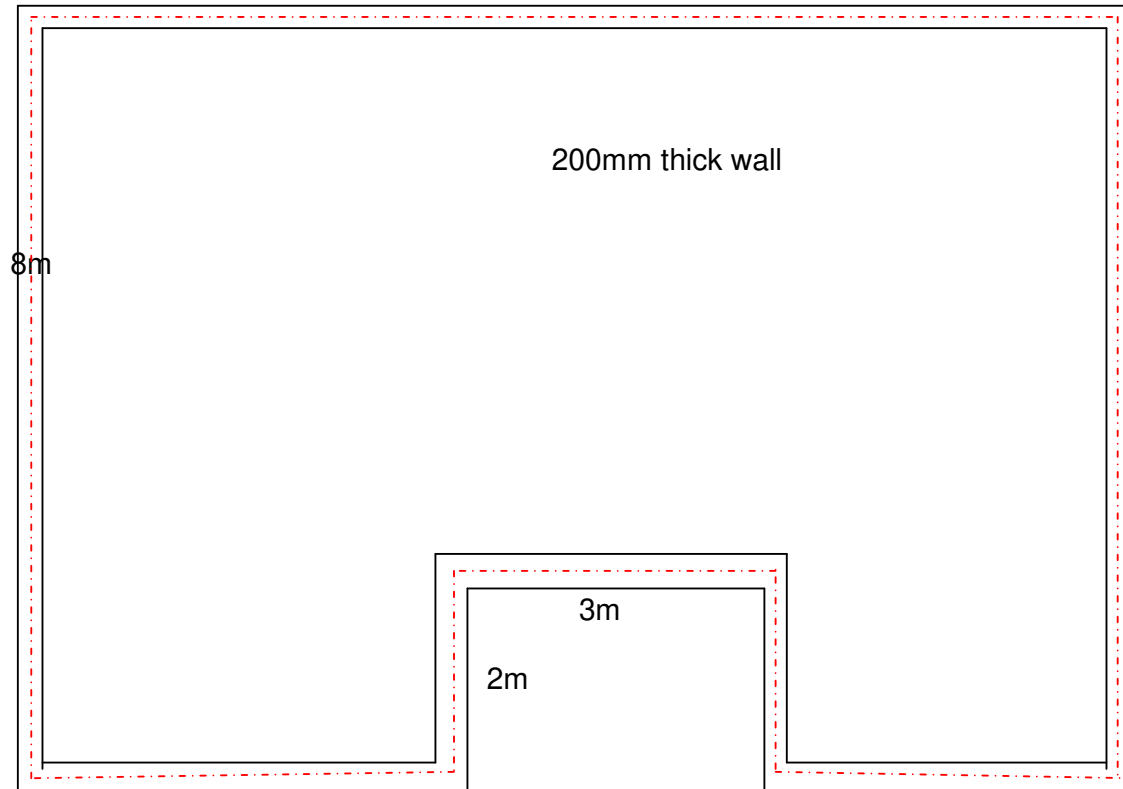



			<u>Centre Line</u>		
			2/10.000	20.000	2 x length A drag of the 3.50m length to complete the 10m run on the length
			2/8.000	<u>16.000</u>	2 x width A drag of the 2.50m length to complete the 8m run on the breadth
				36.000	The 3.00m horizontal in the recess drops down to fill up the 10.00m on the length.
			<u>Add</u>		This leaves us with the pair of 2.00m of the recess overhanging in the plan.
			2/2.000	<u>4.000</u>	
			External wall perimeter	40.000	This forms the only excess to the original rectangular shape
			<u>Ddt</u>		Adjustment for the corners is always made on the basis of how many corners there are in the shape.
			4/2 <sup>1/2</sup> /200	<u>0.800</u>	To determine the number of corners, we count the external corners as +ve and the internal corners as -ve
				<u>39.200</u>	+6 x external corners -2 x internal corners
					This gives us a net +4 corners

			<p><b>RULE 2</b></p> <p><b>AN ALONG THE WALL RECESS ALTERS THE PERIMETER OF THE SHAPE BY 2 X THE DEPTH OF THE RECESS</b></p>	
			<p>This explains why an irregular shape is likely to be more expensive to build than a regular shape as greater amount of excavation and foundation work on the irregular shape is required while at the same time, the irregular shape provides a lesser usable floor area.</p>	

## **CLASS EXERCISE**

1. Give students a couple of rectangular shapes with recesses at two or more locations along the wall (all dimensions given) to work out the centre line for the recessed shape.

## WEEK 12: CENTRE LINE GIRTH III

### 12.1 More complex shapes

Rectangular plan shape with a recess along the wall and recess at a corner

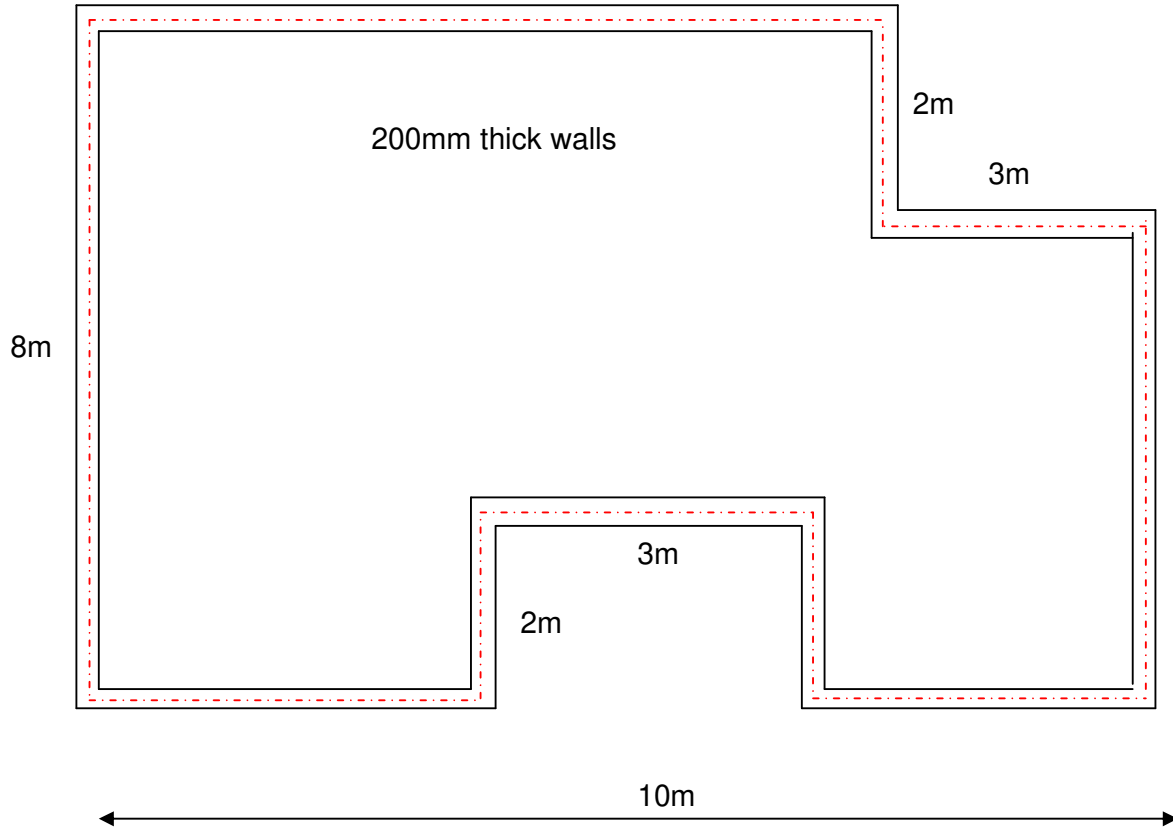

			<u>Centre Line</u>		
			2/10.000	20.0000	2 x length A drag of the 3.50m length to complete the 10m run on the length
			2/8.000	<u>16.000</u>	2 x width A drag of the 2.50m length to complete the 8m run on the breadth
				36.000	The 3.00m horizontal in the along wall recess drops down to fill up the 10.00m on the length.
			<u>Add</u>		This leaves us with the pair of 2.00m of the along wall recess overhanging in the plan.
			2/2.000	<u>4.000</u>	
				40.000	This forms the only excess to the original rectangular shape
					The corner recess has the same NIL effect as always. Therefore no adjustment is to be made to the computation as a result of a corner recess
			<u>Ddt</u>		Adjustment for the corners is always made on the basis of how many corners there are in the shape.
			4/2 <sup>1/2</sup> /200	<u>0.800</u>	
				<u>39.200</u>	To determine the number of corners, we count the external corners as +ve and the internal corners as -ve
					+7 x external corners -3 x internal corners This gives us a net +4 corners

### RULE 3

A MIX OF A CORNER RECESS AND AN ALONG THE WALL RECESS ALTERS THE PERIMETER OF THE OF THE SHAPE BY 2 X THE DEPTH OF THE ALONG WALL RECESS. THE CORNER RECESS DOES NOT HAVE ANY AFFECT.

This explains why a more irregular complicated shape is likely to be even more expensive to build than a regular shape as still greater amount of excavation and foundation work on the irregular shape is required while at the same time, the irregular shape provides less and less usable floor area.

## **CLASS EXERCISES**

1. Give students a couple of plan shapes with complicated recesses asking them to count how many external and internal corners are present. Do this until the lecturer is confident that students have a clear understanding of this concept
2. Give students a rectangular shape with recesses at two or more locations along the wall (all dimensions given) to work out the centre line for the recessed shape.

## **WEEK 13: BESMM3 RULES FOR EXCAVATION AND EARTHWORK I**

### **13.1 Work group D Groundwork**

This work section is covered by Section D20 of the BESMM3 and some of the clauses will be looked at closely over the next three weeks as a prelude to measurement of substructures.

Generally D20: Excavating and filling deals with:

- Forming bulk, pit, trench and surface area excavation other than those for services supplies, M & E services and drainage;
- Filling holes and excavations other than those for services, etc. and
- Making up levels by bulk filling or in layers, including hardcore but excluding bases and sub bases to roads and pavings

#### **Information Provided, Measurement, Definition and Coverage Rules & Supplementary Information**

D20 Rule PI (e) Features retained would include trees which are retained and protected, stating any required method of protection

D20 rule M3 The volume of material to be excavated can considerably increase after excavation which is known as 'bulking' and the contractor should allow for this when building up rates for disposal and filling since the quantities given in the bill will refer to the bulk before excavating.

D20 Rule M7 This rule explains when it is necessary to measure working space and must be read together with D20:6.1 and D20:6.2-4

D20 Rule D5 Special plant in this context of excavating in rock includes:

- Power operated hammers, drills, and chisels and
- Special attachments to mechanical plant such as rock buckets, rippers, hammers and chisels

D20 Rule C2 This rule refers to the measurement of working space and apart from the additional excavation needed, all the additional items such as earthwork support, disposal, backfilling, work below water level, and breaking out required as a result of the excavation of working space are deemed to be included in the with the item.



### Deemed to be included items

The term 'deemed to be included' is used extensively in BESMM3 and indicates that this particular work is covered in the billed item without the need for specific mention. The estimator needs to be aware of these items since he will have to include for them while building up the unit rates.

D20 Rule S1-S9 These are supplementary information that provide additional information to the contractor and could be given in specifications but must be referenced in the description of relevant items

### **Classification Rules**

D20:1.1-2 Site preparation, removing trees and tree stumps

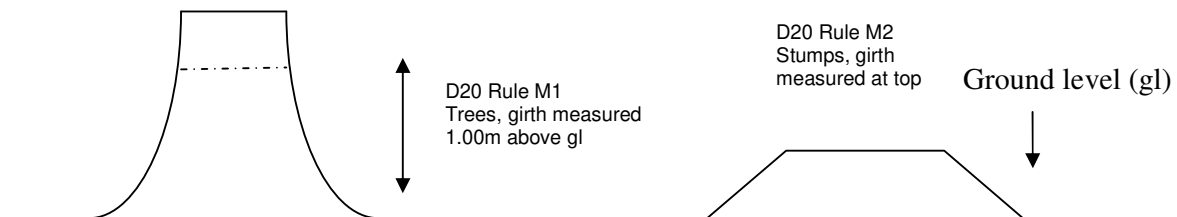

D20.1.1. Removing trees

D20.1.2 Removing stumps

D20.1.3.4 Clearing site vegetation is defined in D20 Rule D1. A full description is required with sufficient detail to allow identification of vegetation types. These items are measured over area (i.e. in square metres)

D20.1.4.1 Turf is a piece of grass sod cut from the ground and preserved for future use. The method of preserving should be given in the specification and referred to in the description.

D20.2.1.1 excavating topsoil for preservation need not be given as a separate item except where it is specified that topsoil is to be preserved.

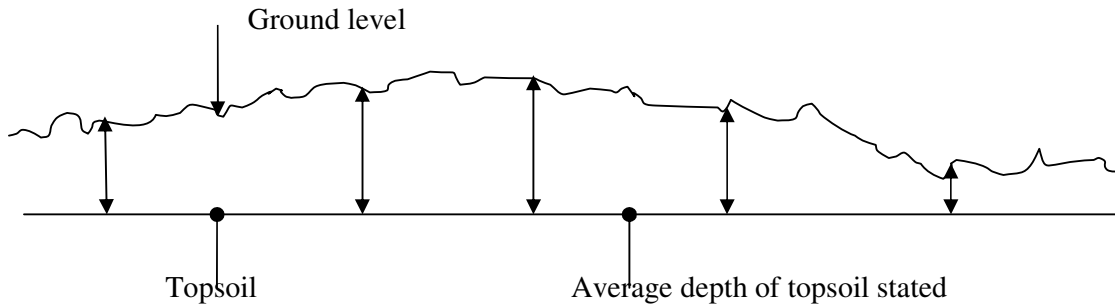

D20.2.2. Excavating to reduce levels

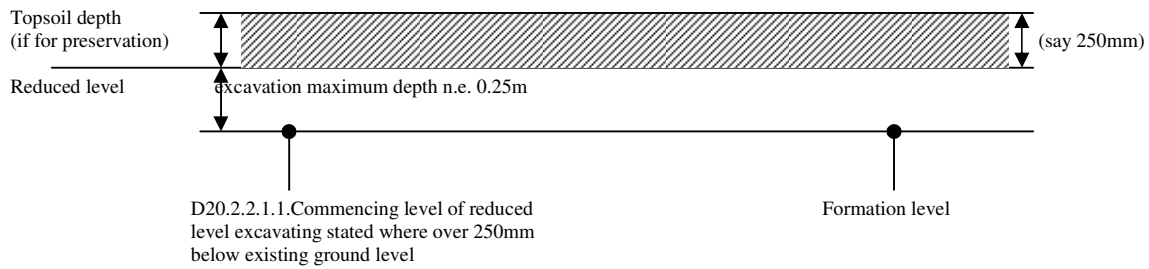

If topsoil is not to be preserved then reduce level excavations commence at existing ground level (gl)

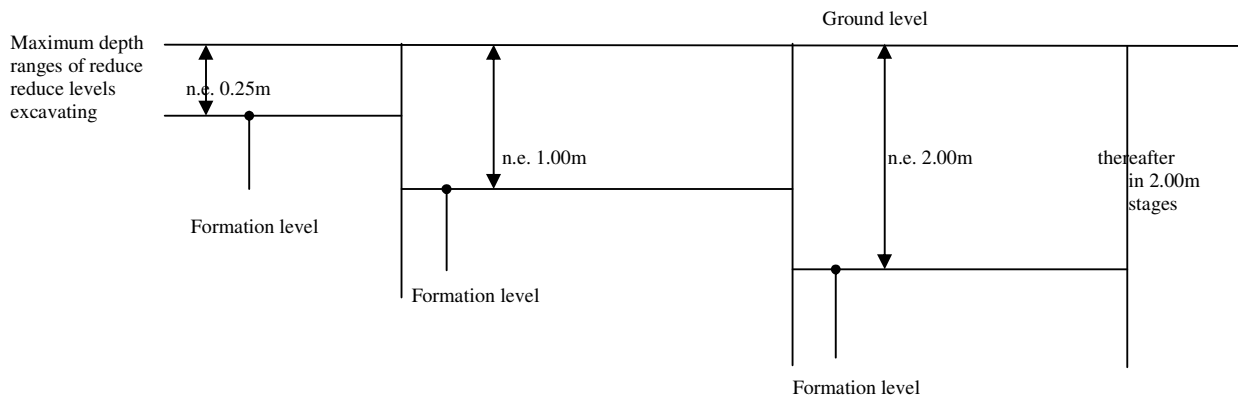

D20.2.3 A basement is a useable area of a building below ground level. These are areas which can be occupied areas, car parks and plant rooms.

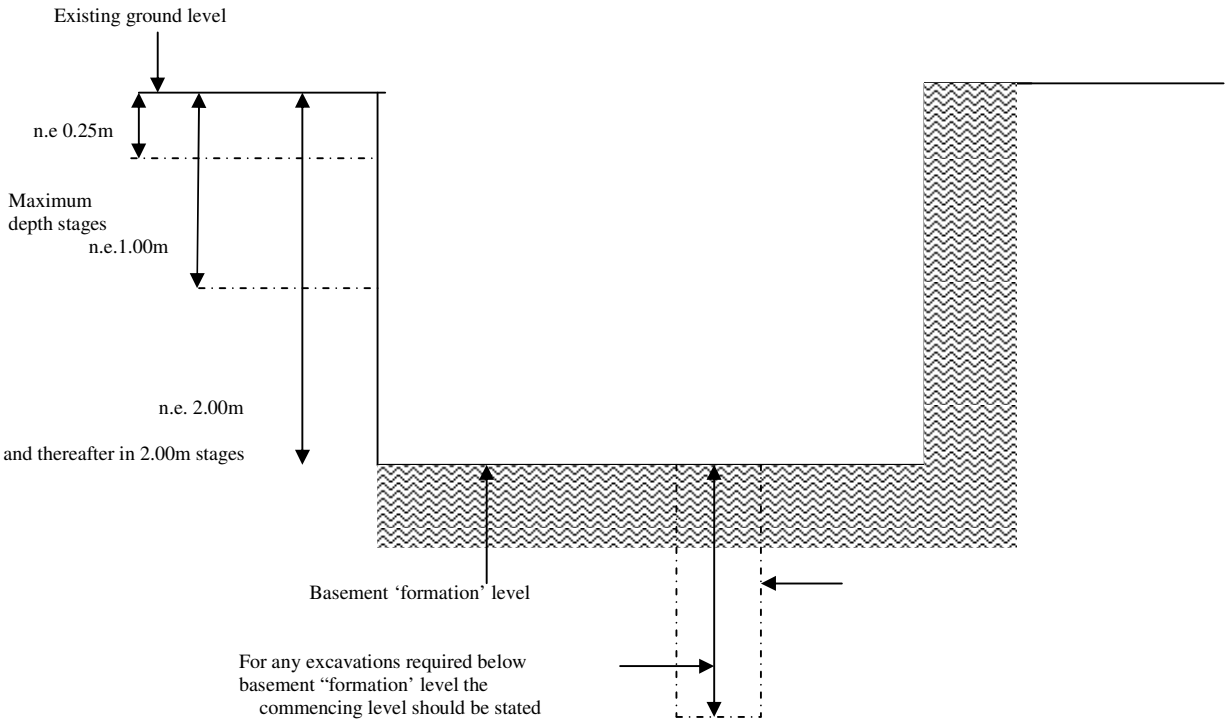

D20.2.4-7 Excavation for pits trenches, pile caps  
 Maximum depth of excavation should be stated in the description in the following stages:

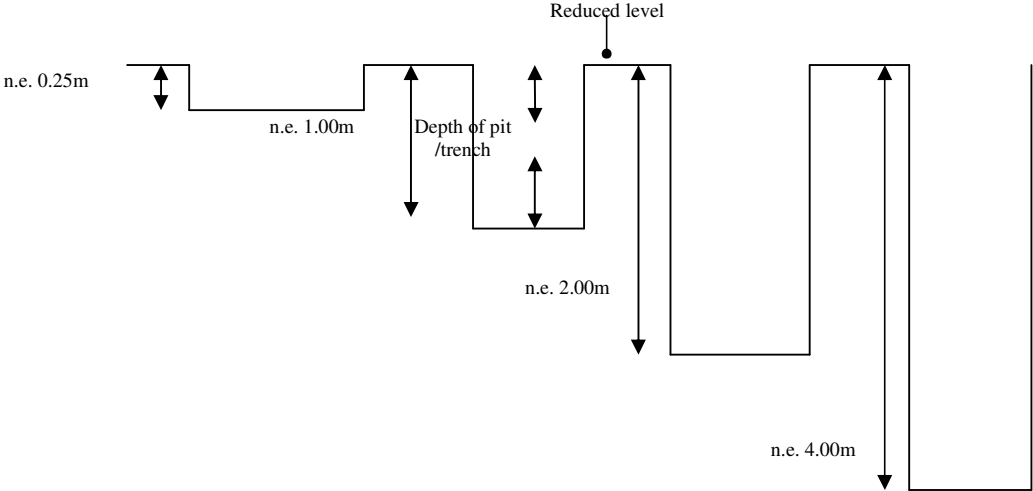

D 20.2.8 Excavating “to bench sloping ground to receive filling” This is done in the face of sloping ground to prevent slippage

D20.3 The rules under this clause cover items extra over any type of excavation irrespective of depth.

Extra over items

When measuring certain items of work, they are described as extra over other items of work previously measured. These are items are not priced at the full value of all their labour and materials by the estimator as these have been measured to some extent elsewhere. Pipe fittings such as bends and junctions, for example, are usually measured as extra over the pipe lengths in which they occur. The estimator is expected to work out the additional cost involved in the second item as compared with the first.

The items under this rule are measured as extra over previously measured excavations:

D20.3.1 Excavating below ground water table

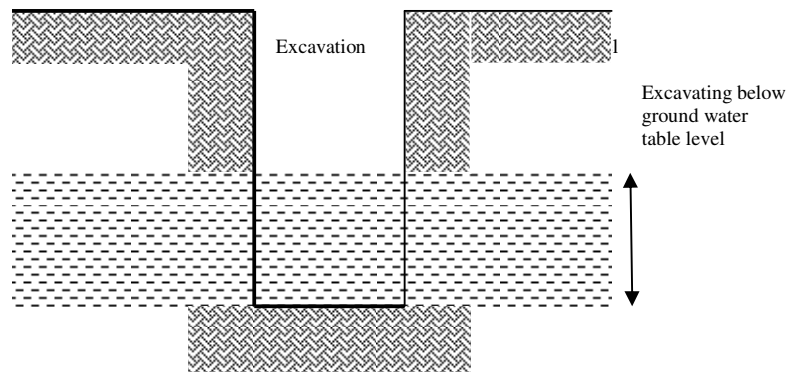

The excavation is measured as if there was no water and then the bit excavated below water level is then measured as extra over the excavation in which it occurs.

D20.3.4.1 Excavating next to existing services

Excavating next to existing services is measured in metres as extra over any types of excavating stating the type of service, such as gas or water mains, electricity or telephone cables or sewers.

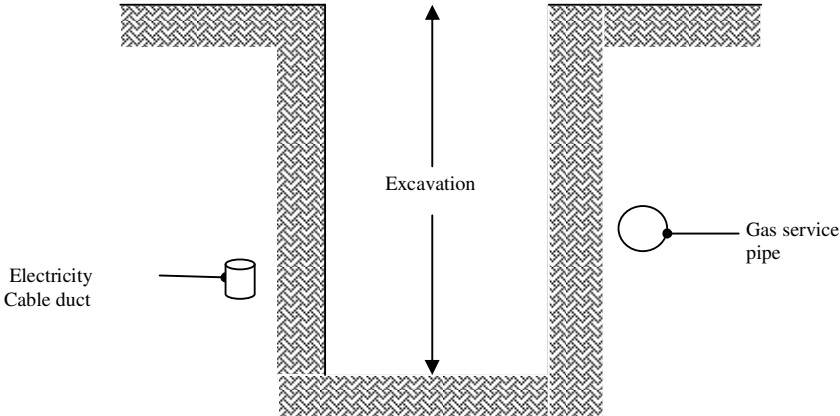

D20.3.5.1 Excavating around existing services crossing excavation

Excavating around existing services crossing excavation is an enumerated extra over item.

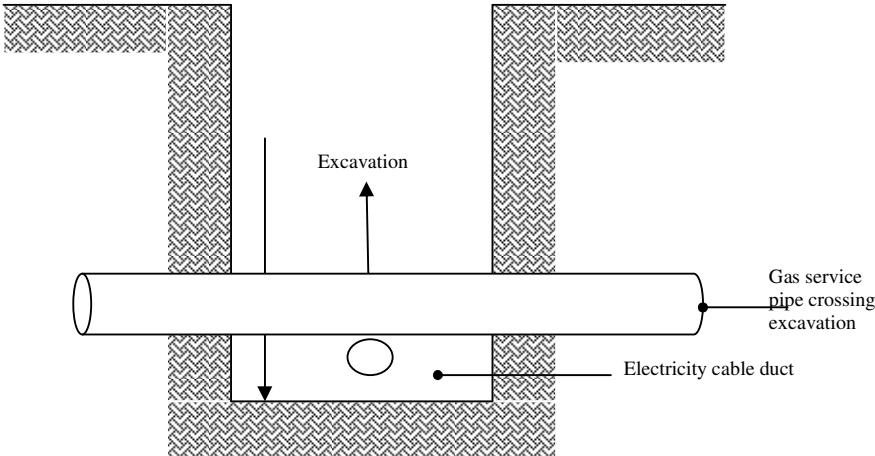

## EXERCISE

Go through all the Groundwork rules and identify the following:

1. All deemed to be included items
2. All extra over items

## WEEK 14: BESMM3 RULES FOR EXCAVATION AND EARTHWORK II

### 14.1 Classification Rules

D20.4. Breaking out existing rock, concrete, reinforced concrete, brickwork, blockwork or stonework shall each be measured and described separately in cubic metres as extra over any types of excavating

Rock is defined as any material which is of such size or position that it can only be removed by special plant or explosives (D20: Definition Rule 5). Special plant are defined as mentioned last week

D20.5. Breaking out existing hard pavings of reinforced concrete, brickwork, blockwork or stonework, coated macadam or asphalt is measured in square metres stating the thickness.

D20.6 Working space allowance to excavations

Working space is no longer measured in detail and this information is provided to enable contractors to make their own allowance based on this and other information provided.

Working space allowance to excavations, categorised in four types of excavations is measured in square metres where the face of the excavation is less than 600mm from the face of formwork, rendering, tanking or protective walls. The four types of excavation are:

- Reduce levels, basements and the like
- Pits
- Trenches
- Pile caps and ground beams between piles

The measurement is taken as the girth or length of the formwork, rendering, tanking or protective wall, multiplied by the height measured from the commencing level of excavation to the bottom of the formwork, etc.

Note: An area is measured not a volume as the estimator is left to make a judgement as to the width required giving due regard to the nature of the work involved.

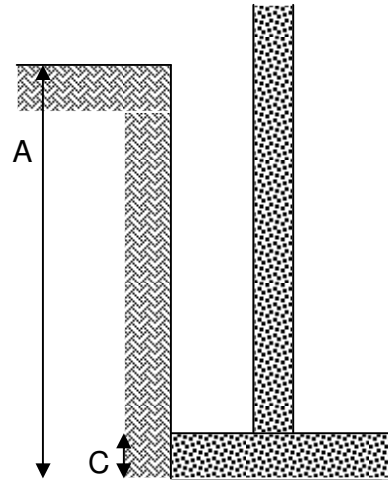

If formwork required to face C, then working space is measured as:

Length or girth of the formwork on plan multiplied by height of the excavation A

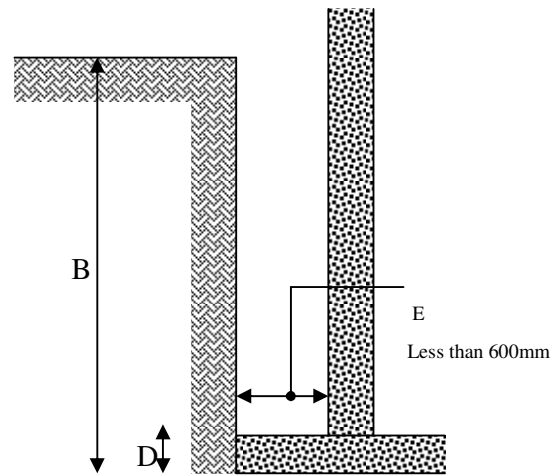



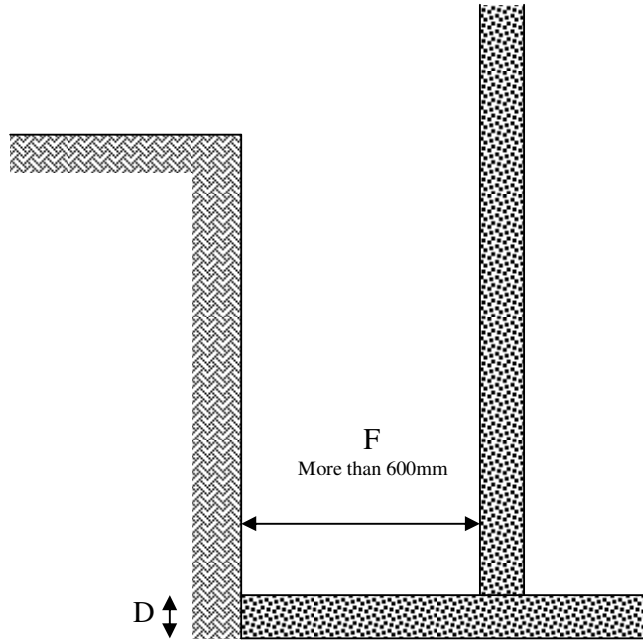

If no formwork is required to face D and if F is more than 600mm then no working space is measured.

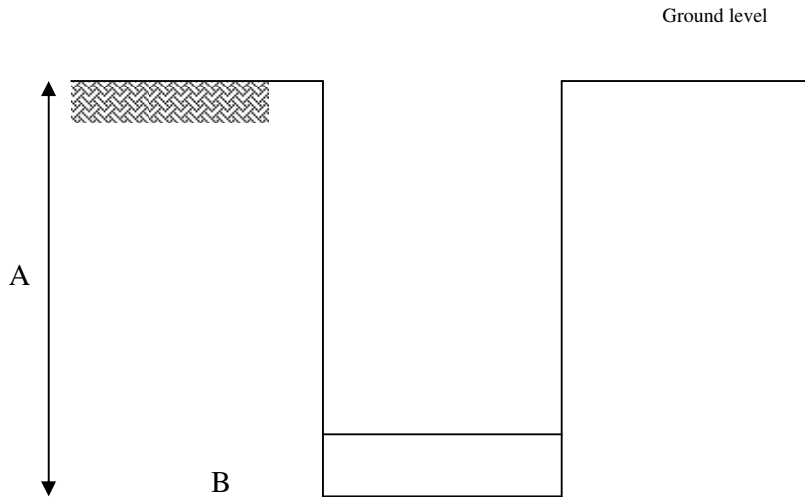

Section of pit/trench/pile caps and ground beams

If the formwork is required to face B, the edge of the concrete foundation, then the working space is measured to the full depth of the pit/trench. If no formwork is required to face b then no working space allowance to excavation is measured.

## D20.7 Earthwork Support

Earthwork support must be measured to the face of any excavation to be upheld whether it will actually be required or not. This is to cover the contractor's responsibility to uphold the sides of excavations. It is left to the contractor's discretion to decide the extent and strength of support required or to use no support at all after due consideration of the nature of the soil.

Earthwork support is measured in square metres to the whole face of excavations in trenches, pits and the like except for excavations not exceeding 250mm depth and pipe trenches which are measured linear. Earthwork support to pipe trenches is deemed to be included in the item. Maximum depth is stated in the description in stages. Earthwork support is also classified by the distance between opposing faces:

Not exceeding 2.00 metres

2.00m – 4.00 metres

Exceeding 4.00 metres

Earthwork support left in, curved, next to a roadway, below ground water level or to unstable ground shall be described and measured separately.

The various classifications of depth and distance between faces are illustrated as follows:

1. A is less than 1.00m and B is less than 2.00m

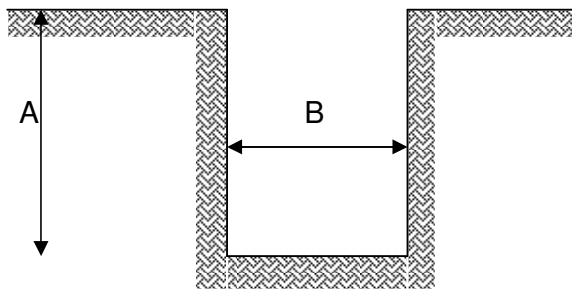

Area of earthwork support = length/girth of excavation x A

Maximum depth not exceeding 1.00m, distance between opposing faces not exceeding 2.00m

2. A is less than 1.00m and B is greater than 2.00m, but less than 4.00m

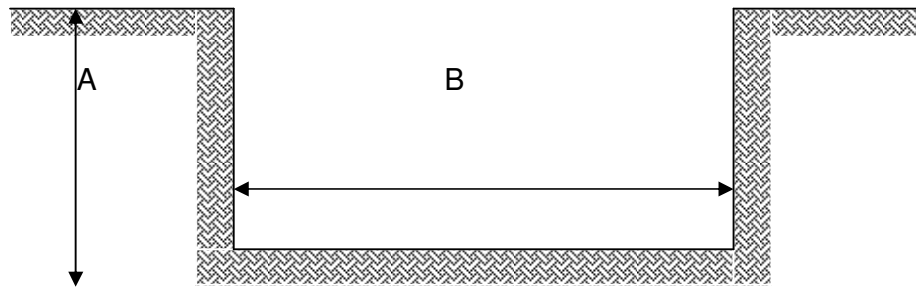

Area of earthwork support = length/girth of excavation x A

Maximum depth not exceeding 1.00m, distance between opposing faces 2.00m – 4.00m

3. A is less than 1.00m and B is greater than 4.00m

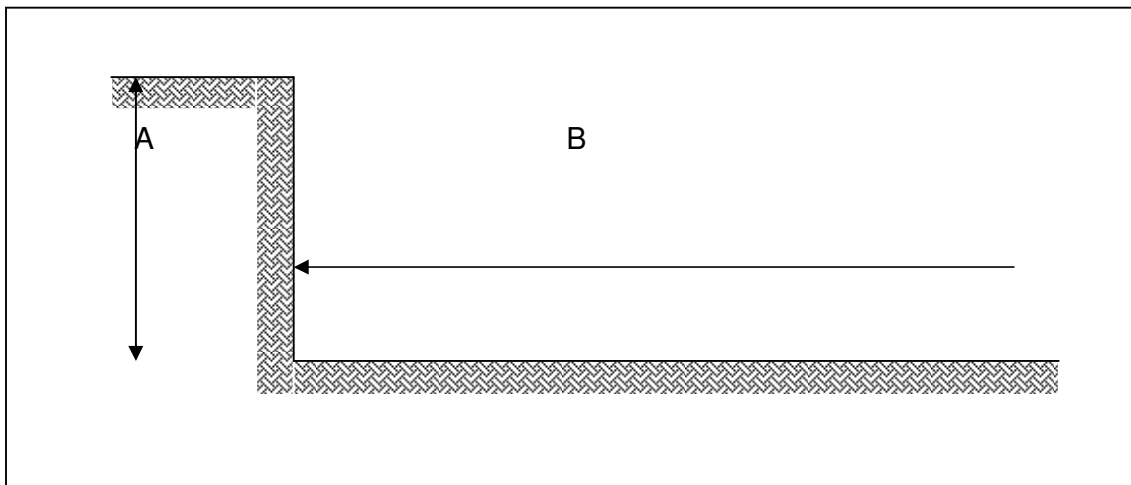

Area of earthwork support = length/girth of excavation x A

Maximum depth not exceeding 1.00m, distance between opposing faces exceeding 4.00m

4. A is greater than 1.00m but less than 2.00m and B is less than 2.00m

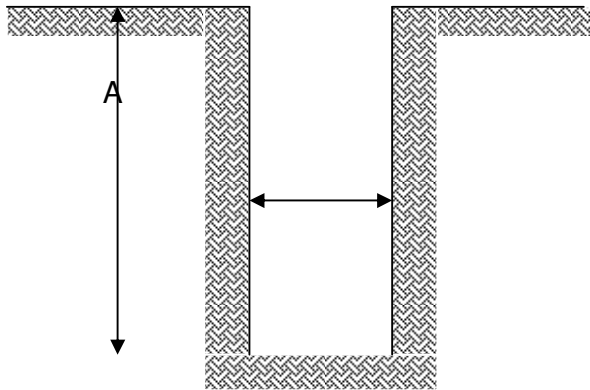

Area of earthwork support = length/girth of excavation x A

Maximum depth not exceeding 2.00m, distance between opposing faces not exceeding 2.00m

5. A is greater than 1.00m but less than 2.00m and B is greater than 2.00m but less than 4.00m

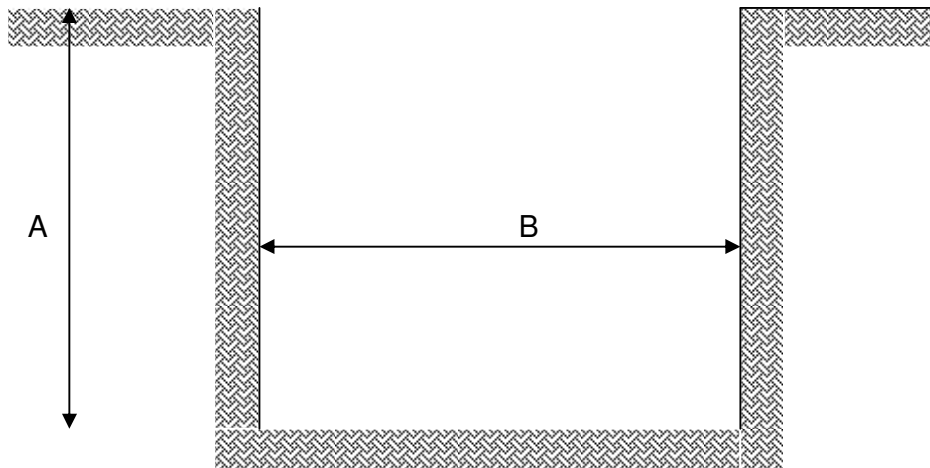

Area of earthwork support = length/girth of excavation x A

Maximum depth not exceeding 2.00m, distance between opposing faces 2.00-4.00m

6. A is greater than 1.00m but less than 2.00m and B is greater than 4.00m

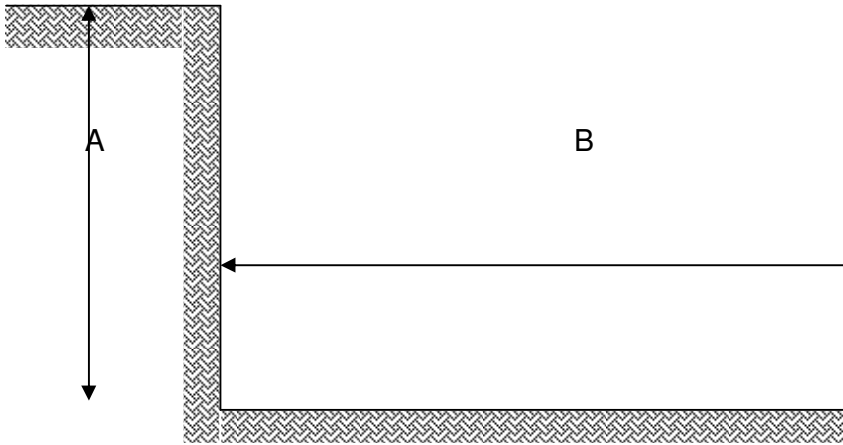

Maximum depth not exceeding 2.00m, distance between opposing faces exceeding 4.00m

7. A is greater than 2.00m but less than 4.00m and B is less than 2.00m

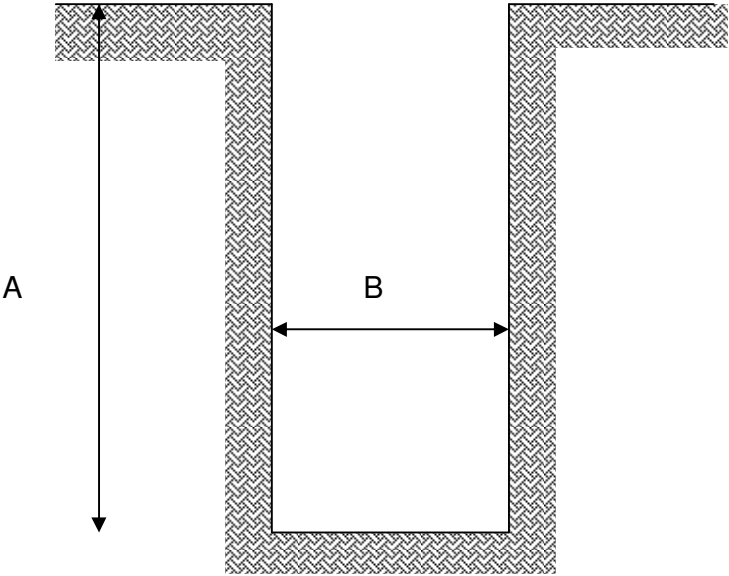

Area of earthwork support = length/girth of excavation x A

Maximum depth not exceeding 4.00m, distance between opposing faces not exceeding 2.00m

8. A is greater than 2.00m but less than 4.00m and B is greater than 2.00m but less than 4.00m

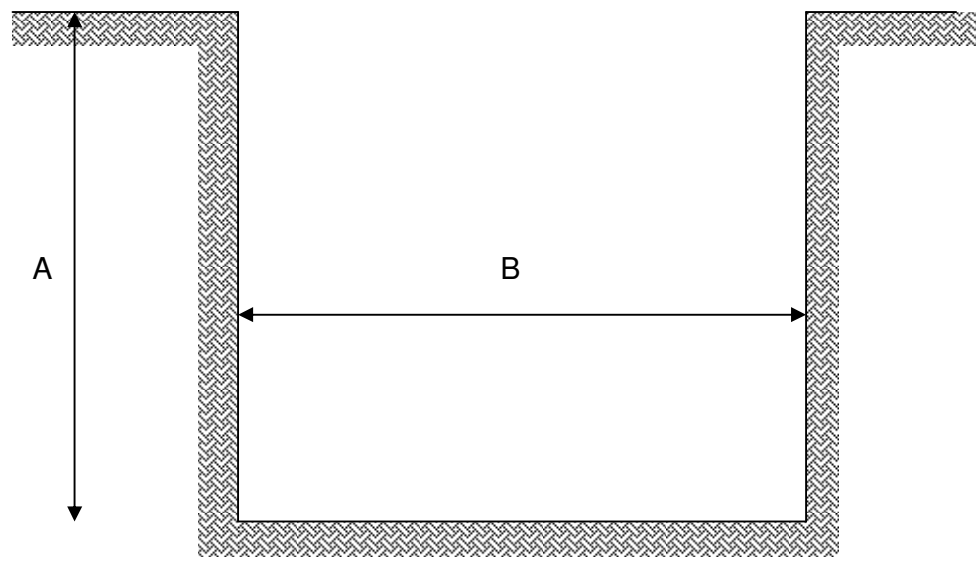

Area of earthwork support = length/girth of excavation x A

Maximum depth not exceeding 4.00m, distance between opposing faces 2.00m – 4.00m

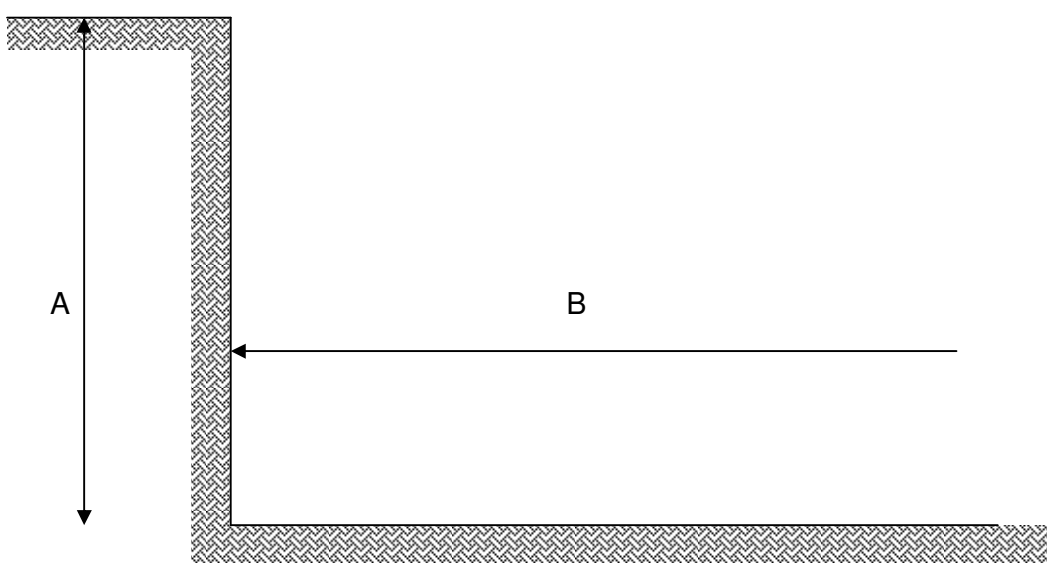

Area of earthwork support = length/girth of excavation x A

Maximum depth not exceeding 4.00m, distance between opposing faces exceeding 4.00m

Depth classification increases in stages of 2.00m thereafter, while for each class the distance between opposing faces alternates between not exceeding 2.00m, 2.00m – 4.00m and exceeding 4.00m

## CLASSROOM EXERCISE

1. A pit has been excavated for a reinforced concrete column base, 1000mm x 2500mm size on plan. Column base will require formwork. Depth of excavation from ground level to underside of column base is 1.85 metres:
  - (a) Sketch a section of the pit excavation
  - (b) Work out the allowance for working space
  - (c) Calculate the area for earthwork support and identify the classifications for maximum depth and distance between opposing faces.
  
2. A foundation trench excavation has a mean length of 56.78m, width, 675mm and depth, 2.20m:  
Calculate the area for earthwork support and identify the classifications for maximum depth and distance between opposing faces.

## WEEK 15: BESMM3 RULES FOR EXCAVATION AND EARTHWORK III

### 15.1 More Classification Rules

#### D20.8.1 Disposal of Surface Water

Surface water is defined as water which runs over the surface of the ground and collects in the excavations. This rule solely applies to rainwater. Water arising from leaking reservoirs or from flooding are examples of accepted risks or matters to be dealt with by insurance.

Disposal of surface water is given as an item. No quantities are required.

#### D20.8.2 Disposal of Ground Water

Ground water is water present in the subsoil which percolates through the sides of the excavation

The ground water level, date when established and location of the trial pits and bore holes must be included in the contract documentation

The level established is defined as the “pre-contract water level” and all measurements in the bills of quantities are based on this level

Disposal of ground water would only be included for pricing as an item where a corresponding item is measured under excavating below water level and is adjusted accordingly if the post contract water level is different.

#### D20. 8.3 Disposal of excavated material

Disposal of excavated material forms a separate item from the excavation itself.

The item is measured in cubic metres and the material may be:

- Stored on site
- Used as filling to make up levels, filling to excavations
- Removed from site

Unless there are specific handling requirements in the specifications or for health and safety regulations in connection with active material’ or ‘toxic/hazardous material’ then the handling of the excavated material will be at the discretion of the contractor.

Where materials are disposed of on site the information provided under the fourth column should state specific requirements for the location of such deposits and the average distance from the excavation in metres.



D20.9-11

## Filling

- Filling to excavations
- Filling to make up levels
- Filling to external planters and the like, position stated

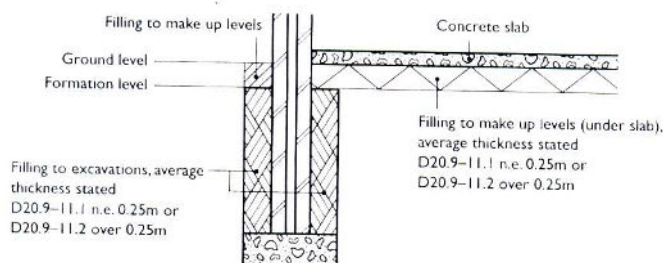

Filling can be obtained from different sources, these should be referred to in the specification particularly in respect of material obtained off site

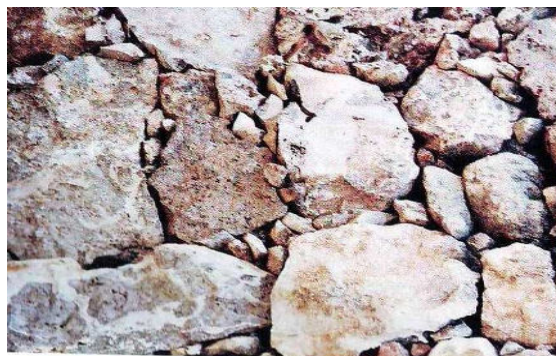

## Surface Treatments

D20.13.1 Applying herbicides is measured over the surface area of the excavation and relates to the use of chemicals to stop the growth of vegetation. Application of anti termite treatment can as well be measured under this rule.

D20.13.2 Compacting would include the former traditional description 'level and ram'. This includes the compacting of bottoms of excavations and compacting of filling and subsequently levelling their surfaces in readiness to receive concrete. Compacting is classified into:

- Compacting ground
- Compacting filling
- Compacting bottom of excavation

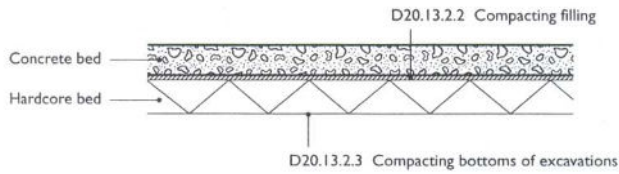

D20.13.2.\*.1 Where blinding is intended to fill the interstices in the filling material only and has no specific thickness then it can be included with surface treatment  
 Specific blinding beds of a given thickness should be measured as 'filling' under item D20.10.3

D20.13.3.1.1 Trimming sloping surfaces is only measured where the slope is greater than 15° from horizontal. If trimming in rock, this should be stated in the description

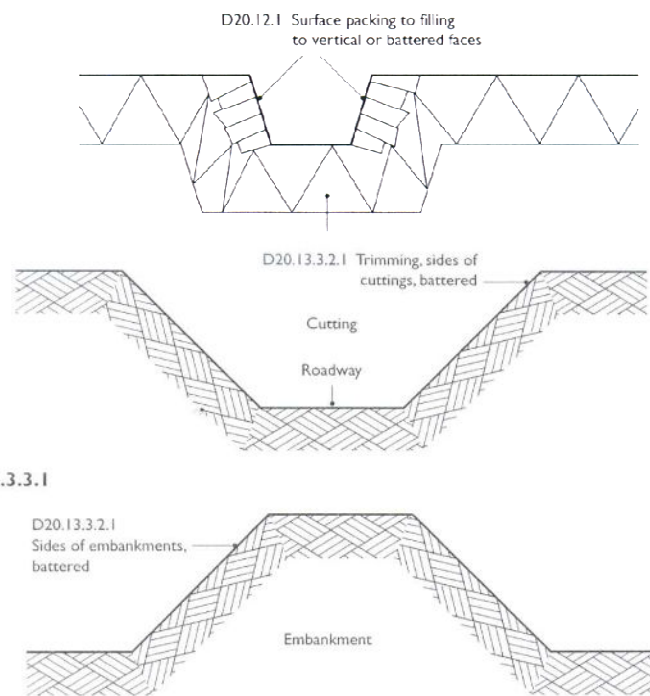

D20.13.4 & 5 Trimming to produce fair or exposed face & preparing subsoil for topsoil  
 The specification should include the requirements and how to achieve these. This should then be referred to in the descriptions.

### **CLASSROOM EXERCISE**

Extract the quantities for excavation, filling and disposal in a few bills of quantities and cross check that:

$$\text{TOTAL VOLUME OF EXCAVATION} = \text{TOTAL VOLUME OF FILLING} + \text{TOTAL VOLUME OF SOIL REMOVED FROM SITE}$$